

LOCATION MAP

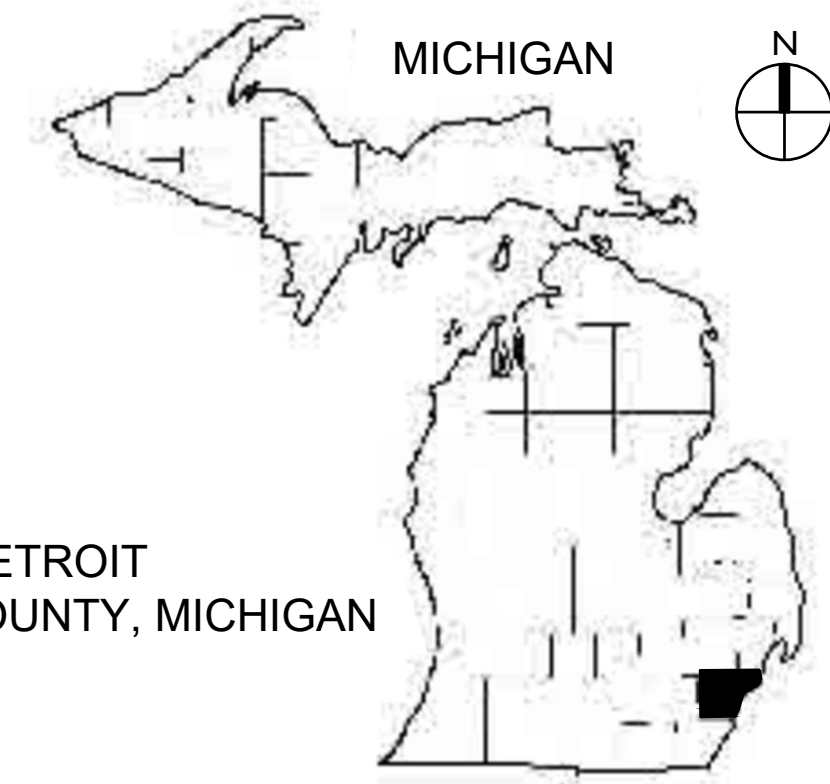

CITY OF DETROIT  
WAYNE COUNTY, MICHIGAN

VACINITY MAP

**PROJECT DESCRIPTION**

Vanguard Community Development Corporation received funding from the Knight Foundation to make streetscape improvements to East Grand Boulevard between Woodward Avenue and I-75 in the Historic North End Detroit neighborhood. The East Grand Boulevard Streetscape Transformation Project developed, with community insight and expertise, a vision and vibe for the boulevard.

# EAST GRAND BOULEVARD STREETScape TRANSFORMATION

E GRAND BLVD  
DETROIT, MI

ISSUED FOR 100% CONSTRUCTION DOCUMENTS, 21 SEPTEMBER 2022

PRIME CONSULTANT  
**SPACKMAN MOSSOP MICHAELS**  
LANDSCAPE ARCHITECTS

CONSULTANT  
**DETROIT COLLABORATIVE DESIGN CENTER**  
MULTIDISCIPLINARY, NON PROFIT DESIGN CENTER

**LIST OF DRAWINGS**

001	COVER SHEET & INDEX	L501	PLANTING PLAN - ZONE 1	L801	MATERIALS ENLARGEMENT PLAN
SP101	TREE DEMO AND PROTECTION PLAN - ZONE 1	L502	PLANTING PLAN - ZONE 2	L802	MATERIALS ENLARGEMENT PLAN
SP102	TREE DEMO AND PROTECTION PLAN - ZONE 2	L503	PLANTING PLAN - ZONE 3	L900	SITE DETAILS
SP103	TREE DEMO AND PROTECTION PLAN - ZONE 3	L504	PLANTING PLAN - ZONE 4	L910	SITE DETAILS, SITE FURNISHINGS
SP104	TREE DEMO AND PROTECTION PLAN - ZONE 4	L505	PLANTING PLAN - ZONE 5	L911	SITE DETAILS, SITE FURNISHINGS
SP105	TREE DEMO AND PROTECTION PLAN - ZONE 5	L506	PLANTING PLAN - ZONE 6	L912	SITE DETAILS, SIGNAGE
SP106	TREE DEMO AND PROTECTION PLAN - ZONE 6	L507	PLANTING PLAN - ZONE 7		
SP107	TREE DEMO AND PROTECTION PLAN - ZONE 7	L550	PLANTING SCHEDULE		
SP900	TREE DEMO AND PROTECTION PLAN DETAILS	L590	PLANTING DETAILS		
L201	MATERIALS PLAN - ZONE 1	L591	PLANTING DETAILS		
L202	MATERIALS PLAN - ZONE 2	L601	IRRIGATION PLAN - ZONE 1		
L203	MATERIALS PLAN - ZONE 3	L602	IRRIGATION PLAN - ZONE 2		
L204	MATERIALS PLAN - ZONE 4	L603	IRRIGATION PLAN - ZONE 3		
L205	MATERIALS PLAN - ZONE 5	L604	IRRIGATION PLAN - ZONE 4		
L206	MATERIALS PLAN - ZONE 6	L605	IRRIGATION PLAN - ZONE 5		
L207	MATERIALS PLAN - ZONE 7	L606	IRRIGATION PLAN - ZONE 6		
L250	SITE FURNISHINGS SCHEDULE	L607	IRRIGATION PLAN - ZONE 7		

**spackman  
mossop  
michaels**  
440 Burroughs Street  
Suite 696  
Detroit | MI | 48202  
T: 313.720.1055  
LANDSCAPE ARCHITECTS

**EAST GRAND BOULEVARD  
STREETScape TRANSFORMATION**  
E GRAND BLVD, DETROIT

**STATUS:**  
100% CONSTRUCTION DOCUMENTS

**DATE:**  
21 SEPTEMBER 2022

**REVISION**  
NO. DESCRIPTION DATE



SMM Project No:  
21014  
Sheet No:  
COVER SHEET & INDEX

Sheet No:  
**001**



**EAST GRAND BOULEVARD  
STREETSCAPE TRANSFORMATION  
E GRAND BLVD, DETROIT**

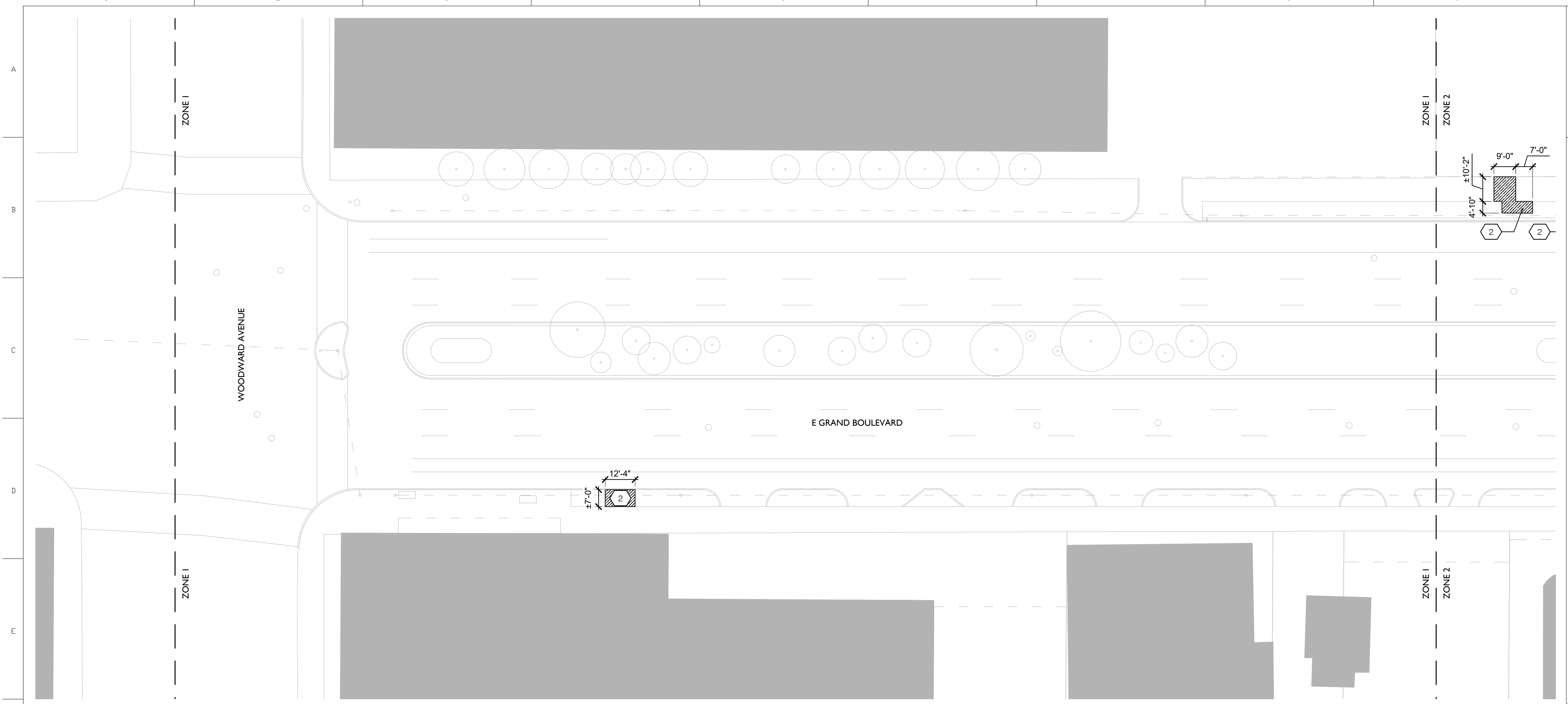

**1** TREE DEMO AND TREE PROTECTION PLAN - ZONE 1  
Scale: 1"=20'-0"

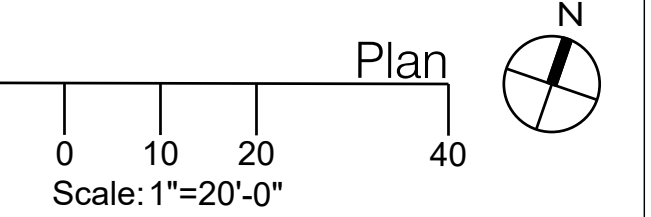

**STATUS:**  
100% CONSTRUCTION DOCUMENTS

**DATE:**  
21 SEPTEMBER 2022

**REVISION**

NO.	DESCRIPTION	DATE



SMM Project No:  
21014

Sheet No:  
**TREE DEMO AND  
TREE PROTECTION  
PLAN ZONE I**

Sheet No:  
**SPI01**

**LEGEND**

- LOW** LIMIT OF WORK
- EXISTING TREES TO REMAIN AND BE PROTECTED
- EXISTING TREES TO BE FULLY REMOVED AND DISPOSED

- TREE PROTECTION FENCE, SEE I/SP900
- REMOVE AND DISPOSE EXISTING GROUND COVER AND/OR CONCRETE SURFACE

**NOTES**

1. ALL FENCES TO PROTECT VEGETATION ARE TO BE INSTALLED BEFORE CONSTRUCTION AND SHALL BE MAINTAINED DURING CONSTRUCTION.
2. WORK DONE WITHIN TREE PROTECTION AREA SHALL BE DONE BY HAND (01 56 39)
3. CONSTRUCTION EQUIPMENT, HEAVY MACHINERY, AND VEHICLES SHALL NOT BE ALLOWED WITHIN TREE PROTECTION FENCING.
4. NO PAINT SHALL BE APPLIED TO VEGETATION TO REMAIN. THE CONTRACTOR SHALL REVIEW THE METHOD OF MARKING VEGETATION TO REMAIN WITH THE LANDSCAPE ARCHITECT PRIOR TO BEGINNING CONSTRUCTION.
5. IMPACTS ON VEGETATION TO REMAIN DURING CONSTRUCTION ARE TO BE KEPT TO A MINIMUM.
6. ALL PROTECTED EXISTING TREES SHALL BE PROPERLY TRIMMED BY A LICENSED ARBORIST: BOOTS ON TRUNKS AND ANY DEAD FRONDS SHALL BE REMOVED; THE CANOPY SHOULD NOT BE LIFTED HIGHER THAN 9 O'CLOCK / 3 O'CLOCK AND PREFERABLY KEPT AT 8 O'CLOCK / 4 O' CLOCK.
7. CONTRACTOR SHALL STRAIGHTEN ANY TILT TREES.
8. ALL TREES, SHRUBS OR PLANTS WITHIN THE LIMITS OF ANY STREET, BOULEVARD, HIGHWAY OR PUBLIC PLACE NEAR ANY EXCAVATION OR CONSTRUCTION OF ANY BUILDING OR STRUCTURE SHALL BE GUARDED WITH A GOOD, SUBSTANTIAL FRAME BOX, NOT LESS THAN 4 FEET SQUARE AND 6 FEET HIGH. ALL BUILDING MATERIAL OR OTHER DEBRIS SHALL BE KEPT AT LEAST 4 FT FROM ANY TREE, SHRUB OR PLANT.
9. DURING THE BIDDING PROCESS, CONTRACTOR SHALL BE RESPONSIBLE FOR VISITING THE SITE TO DETERMINE THE EXTENT OF DEMOLITION, PREPARATION, AND REMOVALS NECESSARY (WHETHER SHOWN ON DRAWINGS OR NOT) TO CONSTRUCT THE PROPOSED SITE IMPROVEMENTS. THE CONTRACTOR SHALL REPORT, IN WRITING, ANY DISCREPANCIES BETWEEN THE EXISTING AND PROPOSED WORK TO THE LANDSCAPE ARCHITECT AND OWNER PRIOR TO PROCEEDING WITH CONSTRUCTION. FAILURE TO INSPECT, NOTICE, OR REPORT THESE DISCREPANCIES PRIOR TO CONSTRUCTION SHALL NOT RELIEVE THE CONTRACTOR FROM HIS RESPONSIBILITY TO PERFORM THE NECESSARY OPERATION FOR THE SUCCESSFUL COMPLETION OF THE PROPOSED IMPROVEMENTS.
10. CONTRACTOR SHALL PROVIDE PROTECTIONS NECESSARY TO PREVENT DAMAGE TO EXISTING IMPROVEMENTS INDICATED TO REMAIN IN PLACE AND NEWLY CONSTRUCTED IMPROVEMENTS ON OWNER'S PROPERTY. THE CONTRACTOR SHALL RESTORE DAMAGED IMPROVEMENTS TO THEIR ORIGINAL CONDITION, AS ACCEPTABLE TO THE LANDSCAPE ARCHITECT AND PARTIES HAVING JURISDICTION, AT NO COST TO THE OWNER AND PARTIES HAVING JURISDICTION.
11. THE CONTRACTOR SHALL CLEAR AND REMOVE ALL ORGANIC MATTER, DEBRIS, AND RUBBISH FROM THE JOB SITE WITHIN AREAS INDICATED AS REMOVE AND DISPOSE EXISTING. THE REMOVAL OF SUCH ITEMS SHALL BE DONE IN A MANNER SO AS NOT TO DAMAGE ITEMS AND VEGETATION TO REMAIN. THE CONTRACTOR SHALL DISPOSE OF SAID MATERIALS IN A LEGAL MANNER.

EAST GRAND BOULEVARD  
STREETSCAPE TRANSFORMATION  
E GRAND BLVD, DETROIT

**1** TREE DEMO AND TREE PROTECTION PLAN - ZONE 2  
Scale: 1"=20'-0"

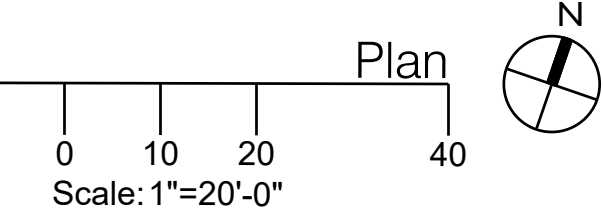

STATUS:  
100% CONSTRUCTION DOCUMENTS

DATE:  
21 SEPTEMBER 2022

REVISION  
NO. DESCRIPTION DATE



SMM Project No:  
21014

Sheet No:  
**TREE DEMO AND  
TREE PROTECTION  
PLAN ZONE 2**

Sheet No:

**SP102**

LEGEND

- LOW LIMIT OF WORK
- EXISTING TREES TO REMAIN AND BE PROTECTED
- EXISTING TREES TO BE FULLY REMOVED AND DISPOSED

- TREE PROTECTION FENCE, SEE 1/SP900
- REMOVE AND DISPOSE EXISTING GROUND COVER AND/OR CONCRETE SURFACE

NOTES

1. ALL FENCES TO PROTECT VEGETATION ARE TO BE INSTALLED BEFORE CONSTRUCTION AND SHALL BE MAINTAINED DURING CONSTRUCTION.
2. WORK DONE WITHIN TREE PROTECTION AREA SHALL BE DONE BY HAND (01 56 39)
3. CONSTRUCTION EQUIPMENT, HEAVY MACHINERY, AND VEHICLES SHALL NOT BE ALLOWED WITHIN TREE PROTECTION FENCING.
4. NO PAINT SHALL BE APPLIED TO VEGETATION TO REMAIN. THE CONTRACTOR SHALL REVIEW THE METHOD OF MARKING VEGETATION TO REMAIN WITH THE LANDSCAPE ARCHITECT PRIOR TO BEGINNING CONSTRUCTION.
5. IMPACTS ON VEGETATION TO REMAIN DURING CONSTRUCTION ARE TO BE KEPT TO A MINIMUM.
6. ALL PROTECTED EXISTING TREES SHALL BE PROPERLY TRIMMED BY A LICENSED ARBORIST: BOOTS ON TRUNKS AND ANY DEAD BRONDS SHALL BE REMOVED; THE CANOPY SHOULD NOT BE LIFTED HIGHER THAN 9 O'CLOCK / 3 O'CLOCK AND PREFERABLY KEPT AT 8 O'CLOCK / 4 O' CLOCK.
7. CONTRACTOR SHALL STRAIGHTEN ANY TILT TREES.
8. ALL TREES, SHRUBS OR PLANTS WITHIN THE LIMITS OF ANY STREET, BOULEVARD, HIGHWAY OR PUBLIC PLACE NEAR ANY EXCAVATION OR CONSTRUCTION OF ANY BUILDING OR STRUCTURE SHALL BE GUARDED WITH A GOOD, SUBSTANTIAL FRAME BOX, NOT LESS THAN 4 FEET SQUARE AND 6 FEET HIGH. ALL BUILDING MATERIAL OR OTHER DEBRIS SHALL BE KEPT AT LEAST 4 FT FROM ANY TREE, SHRUB OR PLANT.
9. DURING THE BIDDING PROCESS, CONTRACTOR SHALL BE RESPONSIBLE FOR VISITING THE SITE TO DETERMINE THE EXTENT OF DEMOLITION, PREPARATION, AND REMOVALS NECESSARY (WHETHER SHOWN ON DRAWINGS OR NOT) TO CONSTRUCT THE PROPOSED SITE IMPROVEMENTS. THE CONTRACTOR SHALL REPORT, IN WRITING, ANY DISCREPANCIES BETWEEN THE EXISTING AND PROPOSED WORK TO THE LANDSCAPE ARCHITECT AND OWNER PRIOR TO PROCEEDING WITH CONSTRUCTION. FAILURE TO INSPECT, NOTICE, OR REPORT THESE DISCREPANCIES PRIOR TO CONSTRUCTION SHALL NOT RELIEVE THE CONTRACTOR FROM HIS RESPONSIBILITY TO PERFORM THE NECESSARY OPERATION FOR THE SUCCESSFUL COMPLETION OF THE PROPOSED IMPROVEMENTS.
10. CONTRACTOR SHALL PROVIDE PROTECTIONS NECESSARY TO PREVENT DAMAGE TO EXISTING IMPROVEMENTS INDICATED TO REMAIN IN PLACE AND NEWLY CONSTRUCTED IMPROVEMENTS ON OWNER'S PROPERTY. THE CONTRACTOR SHALL RESTORE DAMAGED IMPROVEMENTS TO THEIR ORIGINAL CONDITION, AS ACCEPTABLE TO THE LANDSCAPE ARCHITECT AND PARTIES HAVING JURISDICTION, AT NO COST TO THE OWNER AND PARTIES HAVING JURISDICTION.
11. THE CONTRACTOR SHALL CLEAR AND REMOVE ALL ORGANIC MATTER, DEBRIS, AND RUBBISH FROM THE JOB SITE WITHIN AREAS INDICATED AS REMOVE AND DISPOSE EXISTING. THE REMOVAL OF SUCH ITEMS SHALL BE DONE IN A MANNER SO AS NOT TO DAMAGE ITEMS AND VEGETATION TO REMAIN. THE CONTRACTOR SHALL DISPOSE OF SAID MATERIALS IN A LEGAL MANNER.



EAST GRAND BOULEVARD  
STREETSCAPE TRANSFORMATION  
E GRAND BLVD, DETROIT

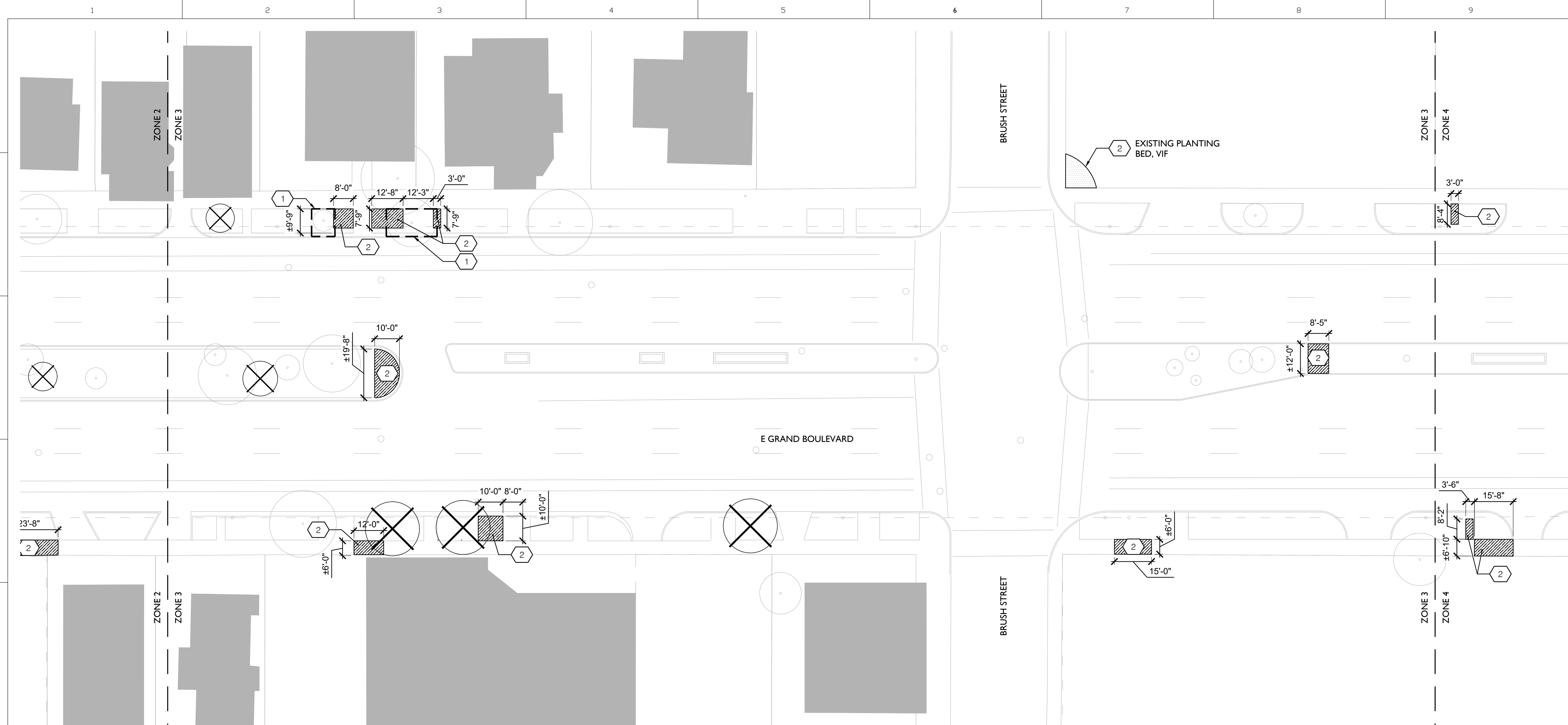

1 TREE DEMO AND TREE PROTECTION PLAN - ZONE 3  
Scale: 1"=20'-0"

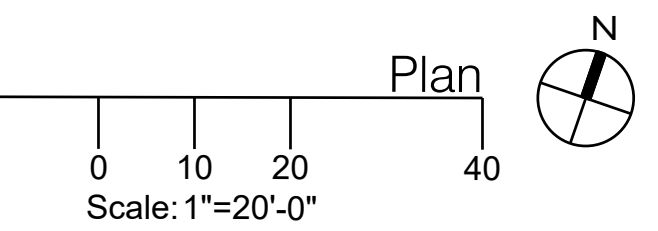

**LEGEND**

	LOW LIMIT OF WORK
	EXISTING TREES TO REMAIN AND BE PROTECTED
	EXISTING TREES TO BE FULLY REMOVED AND DISPOSED

	TREE PROTECTION FENCE, SEE 1/SP900
	REMOVE AND DISPOSE EXISTING GROUND COVER AND/OR CONCRETE SURFACE

- NOTES**
- ALL FENCES TO PROTECT VEGETATION ARE TO BE INSTALLED BEFORE CONSTRUCTION AND SHALL BE MAINTAINED DURING CONSTRUCTION.
  - WORK DONE WITHIN TREE PROTECTION AREA SHALL BE DONE BY HAND (01 56 39)
  - CONSTRUCTION EQUIPMENT, HEAVY MACHINERY, AND VEHICLES SHALL NOT BE ALLOWED WITHIN TREE PROTECTION FENCING.
  - NO PAINT SHALL BE APPLIED TO VEGETATION TO REMAIN. THE CONTRACTOR SHALL REVIEW THE METHOD OF MARKING VEGETATION TO REMAIN WITH THE LANDSCAPE ARCHITECT PRIOR TO BEGINNING CONSTRUCTION.
  - IMPACTS ON VEGETATION TO REMAIN DURING CONSTRUCTION ARE TO BE KEPT TO A MINIMUM.
  - ALL PROTECTED EXISTING TREES SHALL BE PROPERLY TRIMMED BY A LICENSED ARBORIST: BOOTS ON TRUNKS AND ANY DEAD FRONDS SHALL BE REMOVED; THE CANOPY SHOULD NOT BE LIFTED HIGHER THAN 9 O'CLOCK / 3 O'CLOCK AND PREFERABLY KEPT AT 8 O'CLOCK / 4 O' CLOCK.
  - CONTRACTOR SHALL STRAIGHTEN ANY TILT TREES.
  - ALL TREES, SHRUBS OR PLANTS WITHIN THE LIMITS OF ANY STREET, BOULEVARD, HIGHWAY OR PUBLIC PLACE NEAR ANY EXCAVATION OR CONSTRUCTION OF ANY BUILDING OR STRUCTURE SHALL BE GUARDED WITH A GOOD, SUBSTANTIAL FRAME BOX, NOT LESS THAN 4 FEET SQUARE AND 6 FEET HIGH. ALL BUILDING MATERIAL OR OTHER DEBRIS SHALL BE KEPT AT LEAST 4 FT FROM ANY TREE, SHRUB OR PLANT.
  - DURING THE BIDDING PROCESS, CONTRACTOR SHALL BE RESPONSIBLE FOR VISITING THE SITE TO DETERMINE THE EXTENT OF DEMOLITION, PREPARATION, AND REMOVALS NECESSARY (WHETHER SHOWN ON DRAWINGS OR NOT) TO CONSTRUCT THE PROPOSED SITE IMPROVEMENTS. THE CONTRACTOR SHALL REPORT, IN WRITING, ANY DISCREPANCIES BETWEEN THE EXISTING AND PROPOSED WORK TO THE LANDSCAPE ARCHITECT AND OWNER PRIOR TO PROCEEDING WITH CONSTRUCTION. FAILURE TO INSPECT, NOTICE, OR REPORT THESE DISCREPANCIES PRIOR TO CONSTRUCTION SHALL NOT RELIEVE THE CONTRACTOR FROM HIS RESPONSIBILITY TO PERFORM THE NECESSARY OPERATION FOR THE SUCCESSFUL COMPLETION OF THE PROPOSED IMPROVEMENTS.
  - CONTRACTOR SHALL PROVIDE PROTECTIONS NECESSARY TO PREVENT DAMAGE TO EXISTING IMPROVEMENTS INDICATED TO REMAIN IN PLACE AND NEWLY CONSTRUCTED IMPROVEMENTS ON OWNER'S PROPERTY. THE CONTRACTOR SHALL RESTORE DAMAGED IMPROVEMENTS TO THEIR ORIGINAL CONDITION, AS ACCEPTABLE TO THE LANDSCAPE ARCHITECT AND PARTIES HAVING JURISDICTION. AT NO COST TO THE OWNER AND PARTIES HAVING JURISDICTION.
  - THE CONTRACTOR SHALL CLEAR AND REMOVE ALL ORGANIC MATTER, DEBRIS, AND RUBBISH FROM THE JOB SITE WITHIN AREAS INDICATED AS REMOVE AND DISPOSE EXISTING. THE REMOVAL OF SUCH ITEMS SHALL BE DONE IN A MANNER SO AS NOT TO DAMAGE ITEMS AND VEGETATION TO REMAIN. THE CONTRACTOR SHALL DISPOSE OF SAID MATERIALS IN A LEGAL MANNER.

**STATUS:**  
100% CONSTRUCTION DOCUMENTS

**DATE:**  
21 SEPTEMBER 2022

REVISION NO.	DESCRIPTION	DATE



SMM Project No:  
21014

Sheet No:  
**TREE DEMO AND TREE PROTECTION PLAN ZONE 3**

Sheet No:  
**SP103**



EAST GRAND BOULEVARD  
STREETSCAPE TRANSFORMATION  
E GRAND BLVD, DETROIT



1 TREE DEMO AND TREE PROTECTION PLAN - ZONE 4  
Scale: 1"=20'-0"

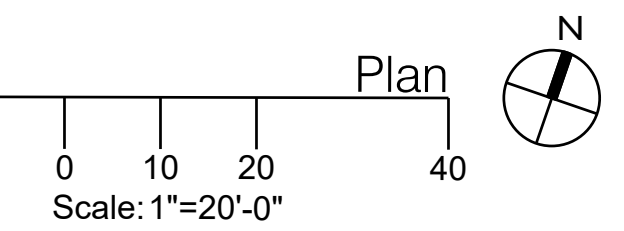

LEGEND

LOW LIMIT OF WORK

EXISTING TREES TO REMAIN AND BE PROTECTED

EXISTING TREES TO BE FULLY REMOVED AND DISPOSED

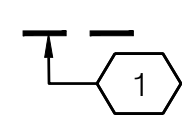

TREE PROTECTION FENCE, SEE 1/SP900



REMOVE AND DISPOSE EXISTING GROUND COVER AND/OR CONCRETE SURFACE

NOTES

- ALL FENCES TO PROTECT VEGETATION ARE TO BE INSTALLED BEFORE CONSTRUCTION AND SHALL BE MAINTAINED DURING CONSTRUCTION.
- WORK DONE WITHIN TREE PROTECTION AREA SHALL BE DONE BY HAND (01 56 39)
- CONSTRUCTION EQUIPMENT, HEAVY MACHINERY, AND VEHICLES SHALL NOT BE ALLOWED WITHIN TREE PROTECTION FENCING.
- NO PAINT SHALL BE APPLIED TO VEGETATION TO REMAIN. THE CONTRACTOR SHALL REVIEW THE METHOD OF MARKING VEGETATION TO REMAIN WITH THE LANDSCAPE ARCHITECT PRIOR TO BEGINNING CONSTRUCTION.
- IMPACTS ON VEGETATION TO REMAIN DURING CONSTRUCTION ARE TO BE KEPT TO A MINIMUM.
- ALL PROTECTED EXISTING TREES SHALL BE PROPERLY TRIMMED BY A LICENSED ARBORIST: BOOTS ON TRUNKS AND ANY DEAD FRONDS SHALL BE REMOVED; THE CANOPY SHOULD NOT BE LIFTED HIGHER THAN 9 O'CLOCK / 3 O'CLOCK AND PREFERABLY KEPT AT 8 O'CLOCK / 4 O' CLOCK.
- CONTRACTOR SHALL STRAIGHTEN ANY TILT TREES.
- ALL TREES, SHRUBS OR PLANTS WITHIN THE LIMITS OF ANY STREET, BOULEVARD, HIGHWAY OR PUBLIC PLACE NEAR ANY EXCAVATION OR CONSTRUCTION OF ANY BUILDING OR STRUCTURE SHALL BE GUARDED WITH A GOOD, SUBSTANTIAL FRAME BOX, NOT LESS THAN 4 FEET SQUARE AND 6 FEET HIGH. ALL BUILDING MATERIAL OR OTHER DEBRIS SHALL BE KEPT AT LEAST 4 FT FROM ANY TREE, SHRUB OR PLANT.
- DURING THE BIDDING PROCESS, CONTRACTOR SHALL BE RESPONSIBLE FOR VISITING THE SITE TO DETERMINE THE EXTENT OF DEMOLITION, PREPARATION, AND REMOVALS NECESSARY (WHETHER SHOWN ON DRAWINGS OR NOT) TO CONSTRUCT THE PROPOSED SITE IMPROVEMENTS. THE CONTRACTOR SHALL REPORT, IN WRITING, ANY DISCREPANCIES BETWEEN THE EXISTING AND PROPOSED WORK TO THE LANDSCAPE ARCHITECT AND OWNER PRIOR TO PROCEEDING WITH CONSTRUCTION. FAILURE TO INSPECT, NOTICE, OR REPORT THESE DISCREPANCIES PRIOR TO CONSTRUCTION SHALL NOT RELIEVE THE CONTRACTOR FROM HIS RESPONSIBILITY TO PERFORM THE NECESSARY OPERATION FOR THE SUCCESSFUL COMPLETION OF THE PROPOSED IMPROVEMENTS.
- CONTRACTOR SHALL PROVIDE PROTECTIONS NECESSARY TO PREVENT DAMAGE TO EXISTING IMPROVEMENTS INDICATED TO REMAIN IN PLACE AND NEWLY CONSTRUCTED IMPROVEMENTS ON OWNER'S PROPERTY. THE CONTRACTOR SHALL RESTORE DAMAGED IMPROVEMENTS TO THEIR ORIGINAL CONDITION, AS ACCEPTABLE TO THE LANDSCAPE ARCHITECT AND PARTIES HAVING JURISDICTION, AT NO COST TO THE OWNER AND PARTIES HAVING JURISDICTION.
- THE CONTRACTOR SHALL CLEAR AND REMOVE ALL ORGANIC MATTER, DEBRIS, AND RUBBISH FROM THE JOB SITE WITHIN AREAS INDICATED AS REMOVE AND DISPOSE EXISTING. THE REMOVAL OF SUCH ITEMS SHALL BE DONE IN A MANNER SO AS NOT TO DAMAGE ITEMS AND VEGETATION TO REMAIN. THE CONTRACTOR SHALL DISPOSE OF SAID MATERIALS IN A LEGAL MANNER.

STATUS:  
100% CONSTRUCTION DOCUMENTS

DATE:  
21 SEPTEMBER 2022

REVISION  
NO. DESCRIPTION DATE

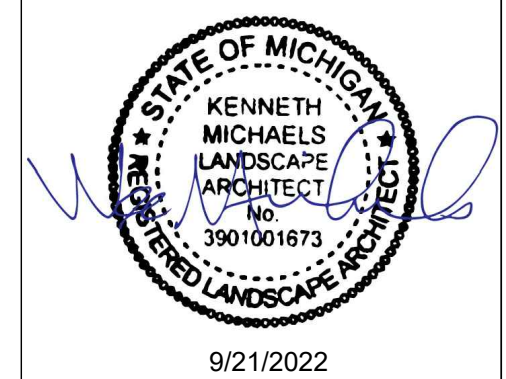

SMM Project No:  
21014

Sheet No:  
TREE DEMO AND  
TREE PROTECTION  
PLAN ZONE 4

Sheet No:  
SP104



**EAST GRAND BOULEVARD  
STREETSCAPE TRANSFORMATION  
E GRAND BLVD, DETROIT**

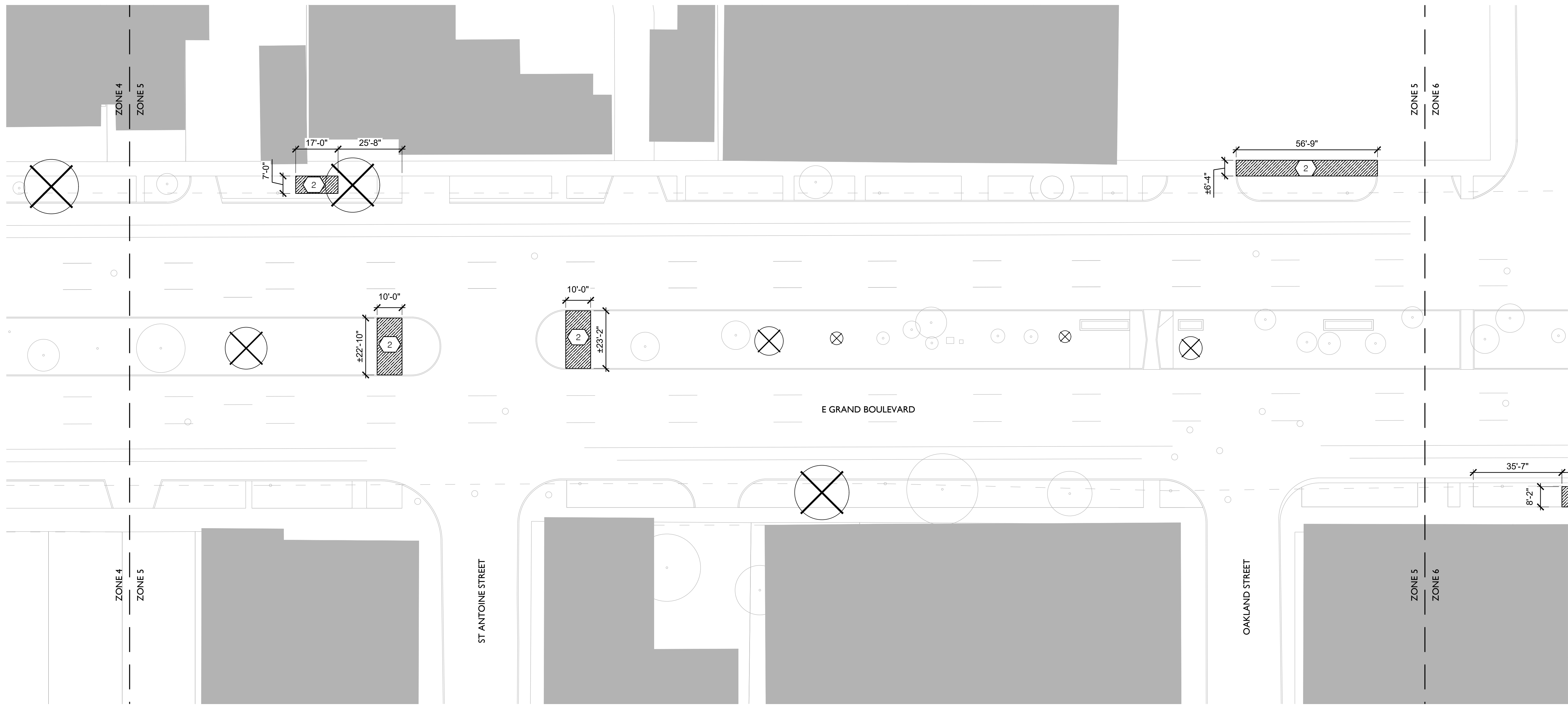

**1 TREE DEMO AND TREE PROTECTION PLAN - ZONE 5**  
Scale: 1"=20'-0"

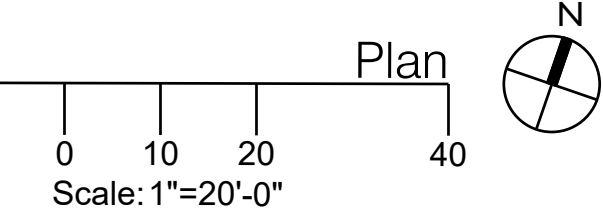

**STATUS:**  
100% CONSTRUCTION DOCUMENTS

**DATE:**  
21 SEPTEMBER 2022

**REVISION**

NO.	DESCRIPTION	DATE

**LEGEND**

- LIMIT OF WORK
- EXISTING TREES TO REMAIN AND BE PROTECTED
- EXISTING TREES TO BE FULLY REMOVED AND DISPOSED

- TREE PROTECTION FENCE, SEE 1/SP900
- REMOVE AND DISPOSE EXISTING GROUND COVER AND/OR CONCRETE SURFACE

**NOTES**

- ALL FENCES TO PROTECT VEGETATION ARE TO BE INSTALLED BEFORE CONSTRUCTION AND SHALL BE MAINTAINED DURING CONSTRUCTION.
- WORK DONE WITHIN TREE PROTECTION AREA SHALL BE DONE BY HAND (01 56 39)
- CONSTRUCTION EQUIPMENT, HEAVY MACHINERY, AND VEHICLES SHALL NOT BE ALLOWED WITHIN TREE PROTECTION FENCING.
- NO PAINT SHALL BE APPLIED TO VEGETATION TO REMAIN. THE CONTRACTOR SHALL REVIEW THE METHOD OF MARKING VEGETATION TO REMAIN WITH THE LANDSCAPE ARCHITECT PRIOR TO BEGINNING CONSTRUCTION.
- IMPACTS ON VEGETATION TO REMAIN DURING CONSTRUCTION ARE TO BE KEPT TO A MINIMUM.
- ALL PROTECTED EXISTING TREES SHALL BE PROPERLY TRIMMED BY A LICENSED ARBORIST: BOOTS ON TRUNKS AND ANY DEAD FRONDS SHALL BE REMOVED; THE CANOPY SHOULD NOT BE LIFTED HIGHER THAN 9 O'CLOCK / 3 O'CLOCK AND PREFERABLY KEPT AT 8 O'CLOCK / 4 O' CLOCK.
- CONTRACTOR SHALL STRAIGHTEN ANY TILT TREES.
- ALL TREES, SHRUBS OR PLANTS WITHIN THE LIMITS OF ANY STREET, BOULEVARD, HIGHWAY OR PUBLIC PLACE NEAR ANY EXCAVATION OR CONSTRUCTION OF ANY BUILDING OR STRUCTURE SHALL BE GUARDED WITH A GOOD, SUBSTANTIAL FRAME BOX, NOT LESS THAN 4 FEET SQUARE AND 6 FEET HIGH. ALL BUILDING MATERIAL OR OTHER DEBRIS SHALL BE KEPT AT LEAST 4 FT FROM ANY TREE, SHRUB OR PLANT.
- DURING THE BIDDING PROCESS, CONTRACTOR SHALL BE RESPONSIBLE FOR VISITING THE SITE TO DETERMINE THE EXTENT OF DEMOLITION, PREPARATION, AND REMOVALS NECESSARY (WHETHER SHOWN ON DRAWINGS OR NOT) TO CONSTRUCT THE PROPOSED SITE IMPROVEMENTS. THE CONTRACTOR SHALL REPORT, IN WRITING, ANY DISCREPANCIES BETWEEN THE EXISTING AND PROPOSED WORK TO THE LANDSCAPE ARCHITECT AND OWNER PRIOR TO PROCEEDING WITH CONSTRUCTION. FAILURE TO INSPECT, NOTICE, OR REPORT THESE DISCREPANCIES PRIOR TO CONSTRUCTION SHALL NOT RELIEVE THE CONTRACTOR FROM HIS RESPONSIBILITY TO PERFORM THE NECESSARY OPERATION FOR THE SUCCESSFUL COMPLETION OF THE PROPOSED IMPROVEMENTS.
- CONTRACTOR SHALL PROVIDE PROTECTIONS NECESSARY TO PREVENT DAMAGE TO EXISTING IMPROVEMENTS INDICATED TO REMAIN IN PLACE AND NEWLY CONSTRUCTED IMPROVEMENTS ON OWNER'S PROPERTY. THE CONTRACTOR SHALL RESTORE DAMAGED IMPROVEMENTS TO THEIR ORIGINAL CONDITION, AS ACCEPTABLE TO THE LANDSCAPE ARCHITECT AND PARTIES HAVING JURISDICTION. AT NO COST TO THE OWNER AND PARTIES HAVING JURISDICTION.
- THE CONTRACTOR SHALL CLEAR AND REMOVE ALL ORGANIC MATTER, DEBRIS, AND RUBBISH FROM THE JOB SITE WITHIN AREAS INDICATED AS REMOVE AND DISPOSE EXISTING. THE REMOVAL OF SUCH ITEMS SHALL BE DONE IN A MANNER SO AS NOT TO DAMAGE ITEMS AND VEGETATION TO REMAIN. THE CONTRACTOR SHALL DISPOSE OF SAID MATERIALS IN A LEGAL MANNER.



SMM Project No:  
21014  
Sheet No:  
**TREE DEMO AND  
TREE PROTECTION  
PLAN ZONE 5**  
Sheet No:  
**SP105**



**EAST GRAND BOULEVARD  
STREETSCAPE TRANSFORMATION**  
E GRAND BLVD, DETROIT

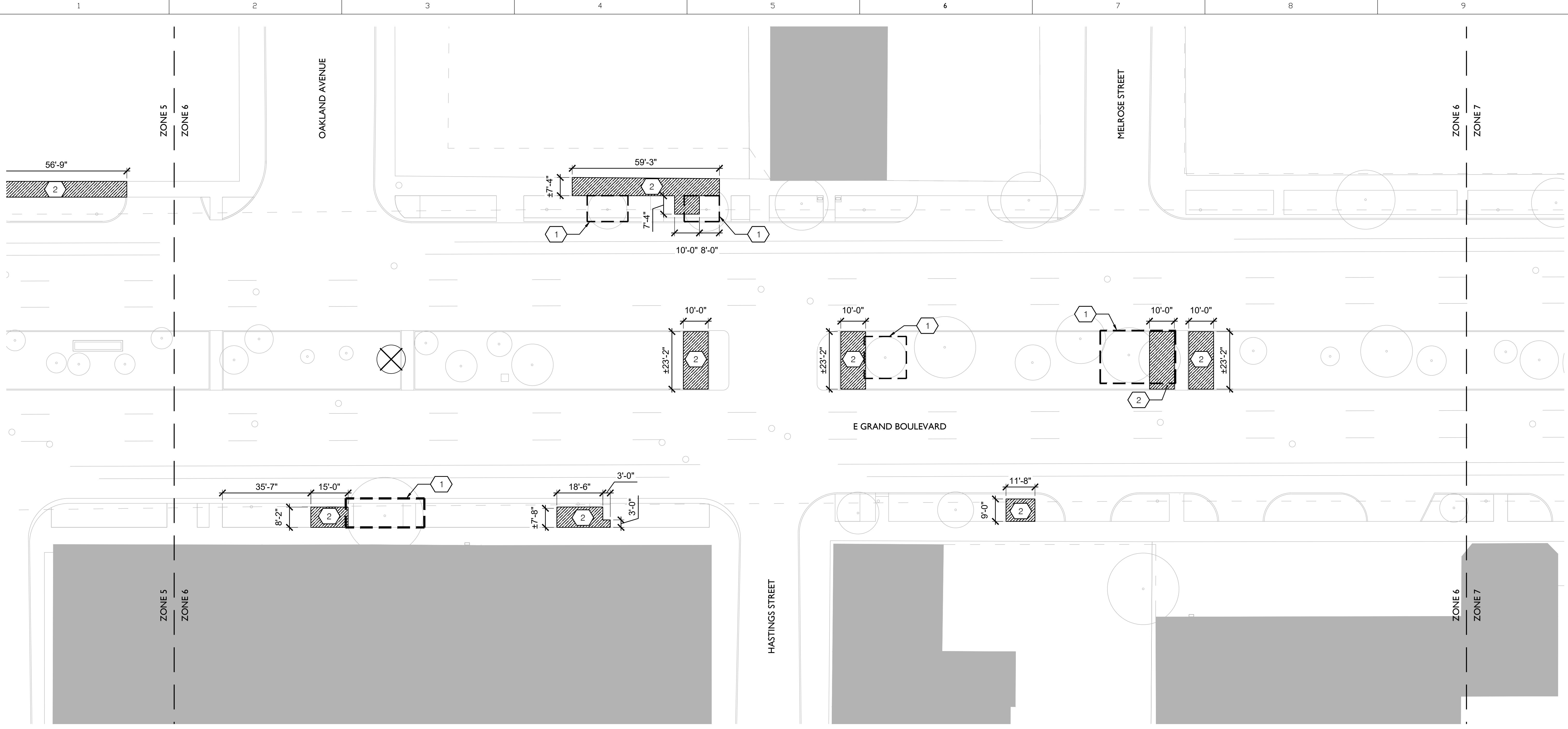

1 TREE DEMO AND TREE PROTECTION PLAN - ZONE 6  
Scale: 1"=20'-0"

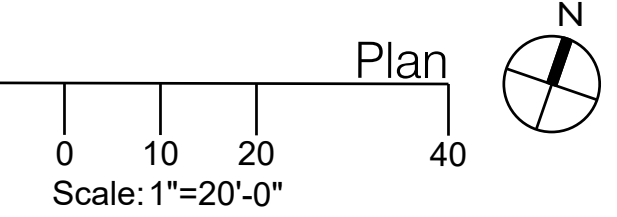

**STATUS:**  
100% CONSTRUCTION DOCUMENTS

**DATE:**  
21 SEPTEMBER 2022

**REVISION**

NO.	DESCRIPTION	DATE

**LEGEND**

- |  |   |  |  |
|--|---|--|--|
|  | LOW LIMIT OF WORK                               |  | TREE PROTECTION FENCE, SEE 1/SP900                               |
|  | EXISTING TREES TO REMAIN AND BE PROTECTED       |  | REMOVE AND DISPOSE EXISTING GROUND COVER AND/OR CONCRETE SURFACE |
|  | EXISTING TREES TO BE FULLY REMOVED AND DISPOSED |  |  |

**NOTES**

- ALL FENCES TO PROTECT VEGETATION ARE TO BE INSTALLED BEFORE CONSTRUCTION AND SHALL BE MAINTAINED DURING CONSTRUCTION.
- WORK DONE WITHIN TREE PROTECTION AREA SHALL BE DONE BY HAND (01 56 39)
- CONSTRUCTION EQUIPMENT, HEAVY MACHINERY, AND VEHICLES SHALL NOT BE ALLOWED WITHIN TREE PROTECTION FENCING.
- NO PAINT SHALL BE APPLIED TO VEGETATION TO REMAIN. THE CONTRACTOR SHALL REVIEW THE METHOD OF MARKING VEGETATION TO REMAIN WITH THE LANDSCAPE ARCHITECT PRIOR TO BEGINNING CONSTRUCTION.
- IMPACTS ON VEGETATION TO REMAIN DURING CONSTRUCTION ARE TO BE KEPT TO A MINIMUM.
- ALL PROTECTED EXISTING TREES SHALL BE PROPERLY TRIMMED BY A LICENSED ARBORIST: BOOTS ON TRUNKS AND ANY DEAD BRONDS SHALL BE REMOVED; THE CANOPY SHOULD NOT BE LIFTED HIGHER THAN 9 O'CLOCK / 3 O'CLOCK AND PREFERABLY KEPT AT 8 O'CLOCK / 4 O' CLOCK.
- CONTRACTOR SHALL STRAIGHTEN ANY TILT TREES.
- ALL TREES, SHRUBS OR PLANTS WITHIN THE LIMITS OF ANY STREET, BOULEVARD, HIGHWAY OR PUBLIC PLACE NEAR ANY EXCAVATION OR CONSTRUCTION OF ANY BUILDING OR STRUCTURE SHALL BE GUARDED WITH A GOOD, SUBSTANTIAL FRAME BOX, NOT LESS THAN 4 FEET SQUARE AND 6 FEET HIGH. ALL BUILDING MATERIAL OR OTHER DEBRIS SHALL BE KEPT AT LEAST 4 FT FROM ANY TREE, SHRUB OR PLANT.
- DURING THE BIDDING PROCESS, CONTRACTOR SHALL BE RESPONSIBLE FOR VISITING THE SITE TO DETERMINE THE EXTENT OF DEMOLITION, PREPARATION, AND REMOVALS NECESSARY (WHETHER SHOWN ON DRAWINGS OR NOT) TO CONSTRUCT THE PROPOSED SITE IMPROVEMENTS. THE CONTRACTOR SHALL REPORT, IN WRITING, ANY DISCREPANCIES BETWEEN THE EXISTING AND PROPOSED WORK TO THE LANDSCAPE ARCHITECT AND OWNER PRIOR TO PROCEEDING WITH CONSTRUCTION. FAILURE TO INSPECT, NOTICE, OR REPORT THESE DISCREPANCIES PRIOR TO CONSTRUCTION SHALL NOT RELIEVE THE CONTRACTOR FROM HIS RESPONSIBILITY TO PERFORM THE NECESSARY OPERATION FOR THE SUCCESSFUL COMPLETION OF THE PROPOSED IMPROVEMENTS.
- CONTRACTOR SHALL PROVIDE PROTECTIONS NECESSARY TO PREVENT DAMAGE TO EXISTING IMPROVEMENTS INDICATED TO REMAIN IN PLACE AND NEWLY CONSTRUCTED IMPROVEMENTS ON OWNER'S PROPERTY. THE CONTRACTOR SHALL RESTORE DAMAGED IMPROVEMENTS TO THEIR ORIGINAL CONDITION, AS ACCEPTABLE TO THE LANDSCAPE ARCHITECT AND PARTIES HAVING JURISDICTION, AT NO COST TO THE OWNER AND PARTIES HAVING JURISDICTION.
- THE CONTRACTOR SHALL CLEAR AND REMOVE ALL ORGANIC MATTER, DEBRIS, AND RUBBISH FROM THE JOB SITE WITHIN AREAS INDICATED AS REMOVE AND DISPOSE EXISTING. THE REMOVAL OF SUCH ITEMS SHALL BE DONE IN A MANNER SO AS NOT TO DAMAGE ITEMS AND VEGETATION TO REMAIN. THE CONTRACTOR SHALL DISPOSE OF SAID MATERIALS IN A LEGAL MANNER.

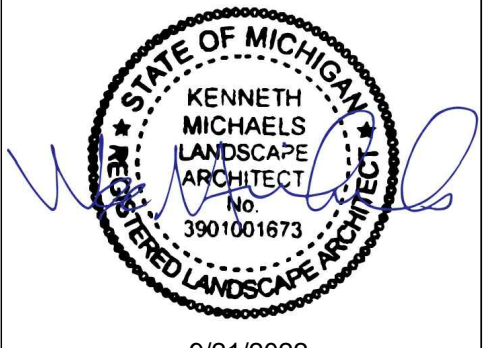

SMM Project No:  
21014

Sheet No:  
**TREE DEMO AND  
TREE PROTECTION  
PLAN ZONE 6**

Sheet No:  
**SP106**



**EAST GRAND BOULEVARD  
STREETSCAPE TRANSFORMATION**  
E GRAND BLVD, DETROIT

**STATUS:**  
100% CONSTRUCTION DOCUMENTS

**DATE:**  
21 SEPTEMBER 2022

**REVISION**

NO.	DESCRIPTION	DATE



SMM Project No:  
21014  
Sheet No:  
**TREE DEMO AND  
TREE PROTECTION  
PLAN ZONE 7**  
Sheet No:

**SP107**

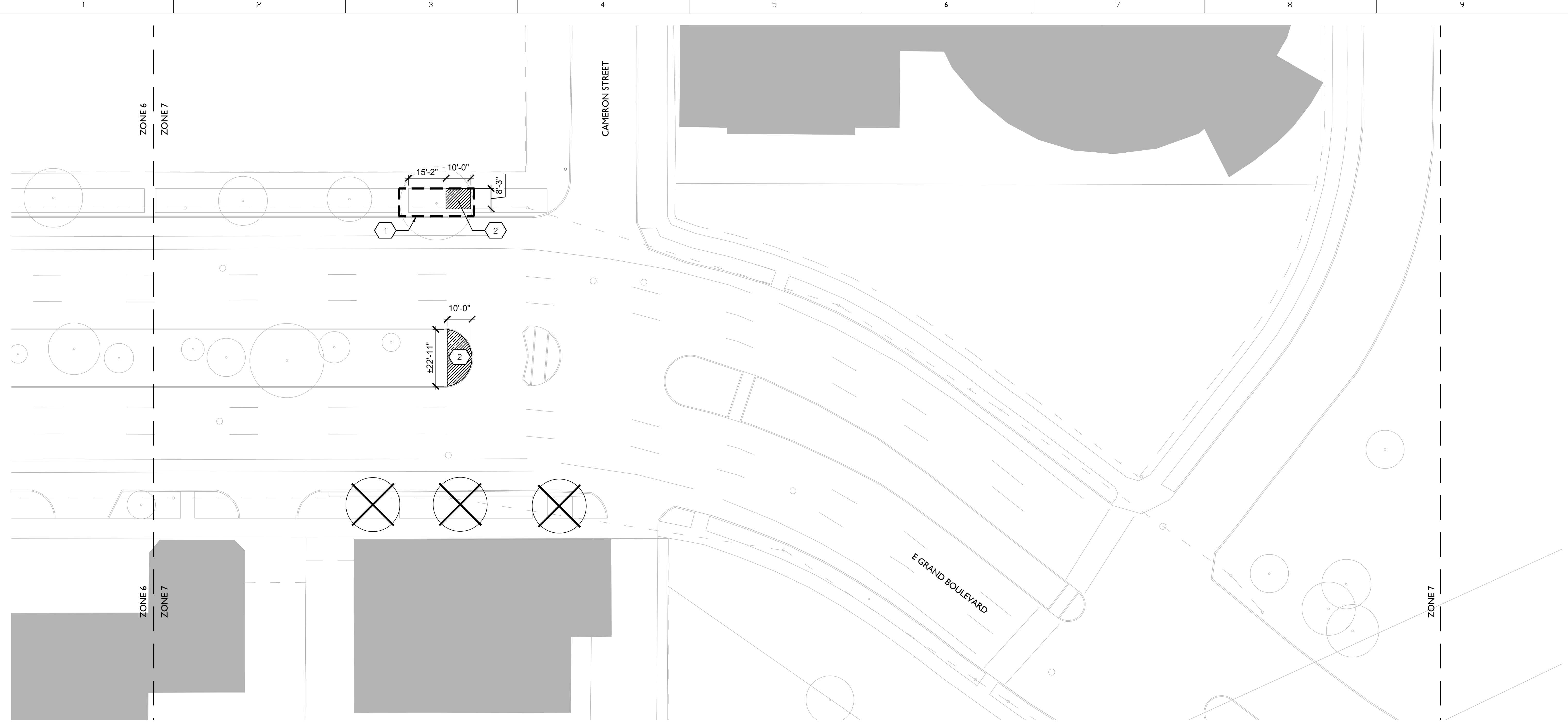

**1** TREE DEMO AND TREE PROTECTION PLAN - ZONE 7  
Scale: 1"=20'-0"

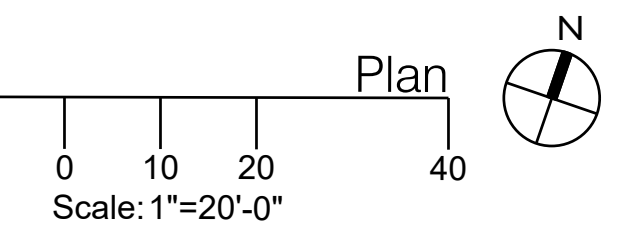

**LEGEND**

	LOW LIMIT OF WORK
	EXISTING TREES TO REMAIN AND BE PROTECTED
	EXISTING TREES TO BE FULLY REMOVED AND DISPOSED

	TREE PROTECTION FENCE, SEE 1/SP900
	REMOVE AND DISPOSE EXISTING GROUND COVER AND/OR CONCRETE SURFACE

- NOTES**
- ALL FENCES TO PROTECT VEGETATION ARE TO BE INSTALLED BEFORE CONSTRUCTION AND SHALL BE MAINTAINED DURING CONSTRUCTION.
  - WORK DONE WITHIN TREE PROTECTION AREA SHALL BE DONE BY HAND (01 56 39)
  - CONSTRUCTION EQUIPMENT, HEAVY MACHINERY, AND VEHICLES SHALL NOT BE ALLOWED WITHIN TREE PROTECTION FENCING.
  - NO PAINT SHALL BE APPLIED TO VEGETATION TO REMAIN. THE CONTRACTOR SHALL REVIEW THE METHOD OF MARKING VEGETATION TO REMAIN WITH THE LANDSCAPE ARCHITECT PRIOR TO BEGINNING CONSTRUCTION.
  - IMPACTS ON VEGETATION TO REMAIN DURING CONSTRUCTION ARE TO BE KEPT TO A MINIMUM.
  - ALL PROTECTED EXISTING TREES SHALL BE PROPERLY TRIMMED BY A LICENSED ARBORIST: BOOTS ON TRUNKS AND ANY DEAD FRONDS SHALL BE REMOVED; THE CANOPY SHOULD NOT BE LIFTED HIGHER THAN 9 O'CLOCK / 3 O'CLOCK AND PREFERABLY KEPT AT 8 O'CLOCK / 4 O' CLOCK.
  - CONTRACTOR SHALL STRAIGHTEN ANY TILT TREES.
  - ALL TREES, SHRUBS OR PLANTS WITHIN THE LIMITS OF ANY STREET, BOULEVARD, HIGHWAY OR PUBLIC PLACE NEAR ANY EXCAVATION OR CONSTRUCTION OF ANY BUILDING OR STRUCTURE SHALL BE GUARDED WITH A GOOD, SUBSTANTIAL FRAME BOX, NOT LESS THAN 4 FEET SQUARE AND 6 FEET HIGH. ALL BUILDING MATERIAL OR OTHER DEBRIS SHALL BE KEPT AT LEAST 4 FT FROM ANY TREE, SHRUB OR PLANT.
  - DURING THE BIDDING PROCESS, CONTRACTOR SHALL BE RESPONSIBLE FOR VISITING THE SITE TO DETERMINE THE EXTENT OF DEMOLITION, PREPARATION, AND REMOVALS NECESSARY (WHETHER SHOWN ON DRAWINGS OR NOT) TO CONSTRUCT THE PROPOSED SITE IMPROVEMENTS. THE CONTRACTOR SHALL REPORT, IN WRITING, ANY DISCREPANCIES BETWEEN THE EXISTING AND PROPOSED WORK TO THE LANDSCAPE ARCHITECT AND OWNER PRIOR TO PROCEEDING WITH CONSTRUCTION. FAILURE TO INSPECT, NOTICE, OR REPORT THESE DISCREPANCIES PRIOR TO CONSTRUCTION SHALL NOT RELIEVE THE CONTRACTOR FROM HIS RESPONSIBILITY TO PERFORM THE NECESSARY OPERATION FOR THE SUCCESSFUL COMPLETION OF THE PROPOSED IMPROVEMENTS.
  - CONTRACTOR SHALL PROVIDE PROTECTIONS NECESSARY TO PREVENT DAMAGE TO EXISTING IMPROVEMENTS INDICATED TO REMAIN IN PLACE AND NEWLY CONSTRUCTED IMPROVEMENTS ON OWNER'S PROPERTY. THE CONTRACTOR SHALL RESTORE DAMAGED IMPROVEMENTS TO THEIR ORIGINAL CONDITION, AS ACCEPTABLE TO THE LANDSCAPE ARCHITECT AND PARTIES HAVING JURISDICTION, AT NO COST TO THE OWNER AND PARTIES HAVING JURISDICTION.
  - THE CONTRACTOR SHALL CLEAR AND REMOVE ALL ORGANIC MATTER, DEBRIS, AND RUBBISH FROM THE JOB SITE WITHIN AREAS INDICATED AS REMOVE AND DISPOSE EXISTING. THE REMOVAL OF SUCH ITEMS SHALL BE DONE IN A MANNER SO AS NOT TO DAMAGE ITEMS AND VEGETATION TO REMAIN. THE CONTRACTOR SHALL DISPOSE OF SAID MATERIALS IN A LEGAL MANNER.



**NOTES:**

1. NO PRUNING SHALL BE PERFORMED EXCEPT BY AN APPROVED ARBORIST.
2. NO EQUIPMENT SHALL OPERATE INSIDE THE PROTECTIVE FENCING, INCLUDING DURING FENCE INSTALLATION AND REMOVAL.
3. SEE TREE PROTECTION PLAN FOR ANY MODIFICATIONS WITH THE TREE PROTECTION AREA.

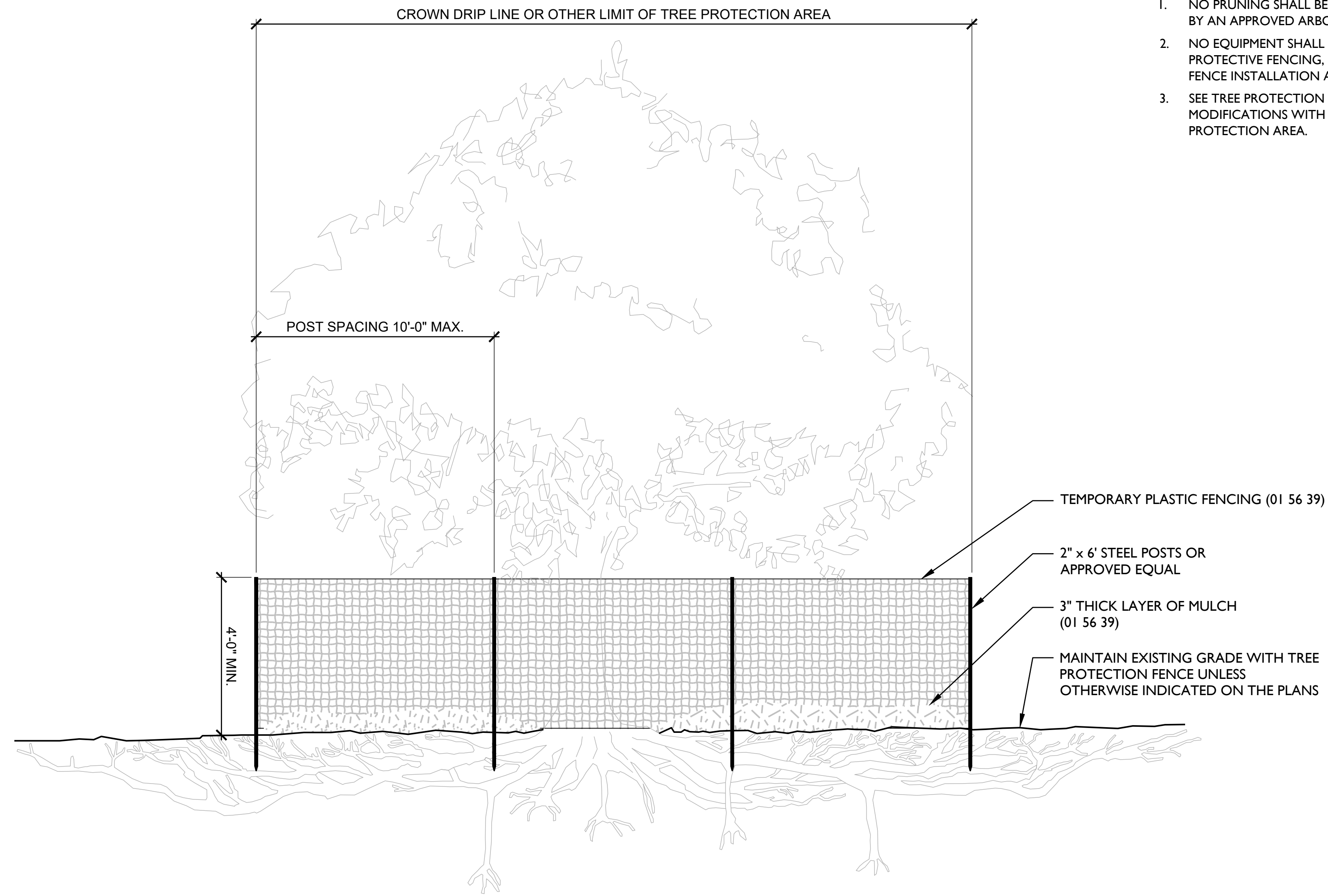

**1** TREE PROTECTION FENCING, TYP.  
Scale: NTS

DETAIL

**STATUS:**  
100% CONSTRUCTION DOCUMENTS

**DATE:**  
21 SEPTEMBER 2022

REVISION NO.	DESCRIPTION	DATE

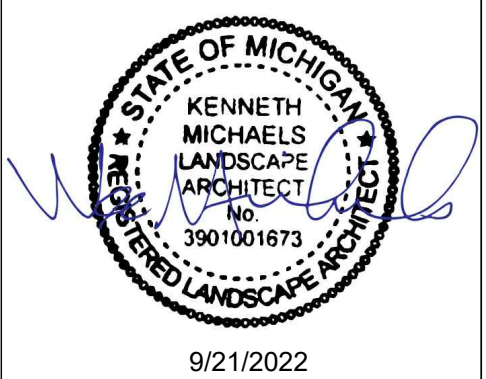

SMM Project No:  
21014

Sheet No:  
**TREE DEMO AND  
TREE PROTECTION  
DETAILS**

Sheet No:  
**SP900**



EAST GRAND BOULEVARD  
STREETSCAPE TRANSFORMATION  
E GRAND BLVD, DETROIT

STATUS:  
100% CONSTRUCTION DOCUMENTS

DATE:  
21 SEPTEMBER 2022

REVISION  
NO. DESCRIPTION DATE



SMM Project No:  
21014

Sheet No:  
**MATERIALS PLAN  
ZONE I**

Sheet No:  
**L201**

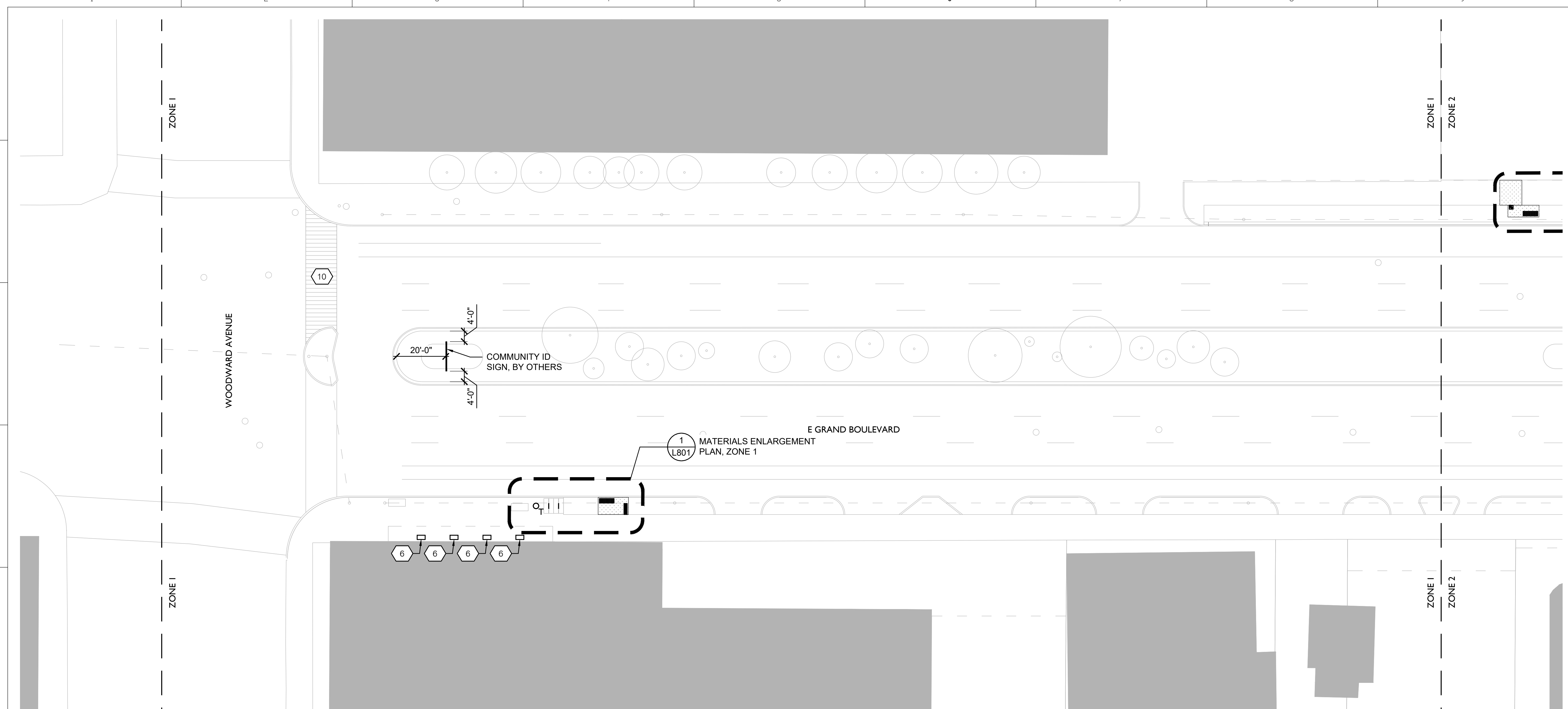

**1** MATERIALS PLAN - ZONE 1  
Scale: 1"=20'-0"

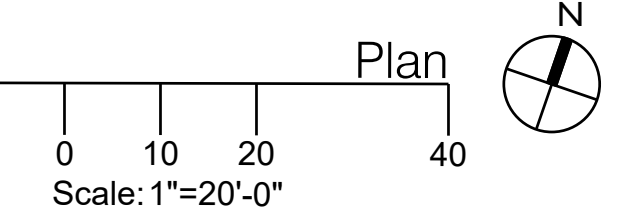

LEGEND

— LOW	LIMIT OF WORK	1 NEW CONCRETE SIDEWALK, SEE 1/L900	4 TRASH CANS, SEE 3/L910	7 BENCH SWING, SEE 1/L911	10 TOUCH UP EXISTING CROSSWALKS, BY CITY
EXISTING TREES TO REMAIN AND BE PROTECTED	2 BENCHES, SEE 2/L910	5 VERTICAL STORYTELLING, SEE 1/L912	8 SOLAR-POWERED CHARGING STATION, SEE 2/L911	11 ARTISTIC CROSSWALKS, SEE 2/L900	
3 BIKE RACKS, SEE 1/L910	6 PLANTERS, SEE L250	9 ART MURAL AT MEDIAN, SEE 3/L900			

NOTES

1. MAINTAIN MAX 4.5% SLOPE AND 2% CROSS SLOPE ACROSS ALL SIDEWALKS.
2. CONTRACTOR TO VERIFY ALL DIMENSIONS IN FIELD.
3. SEE L250 FOR SITE FURNISHINGS SCHEDULE.
4. SEE L900 SERIES FOR DETAILS.



**EAST GRAND BOULEVARD  
STREETSCAPE TRANSFORMATION**  
E GRAND BLVD, DETROIT

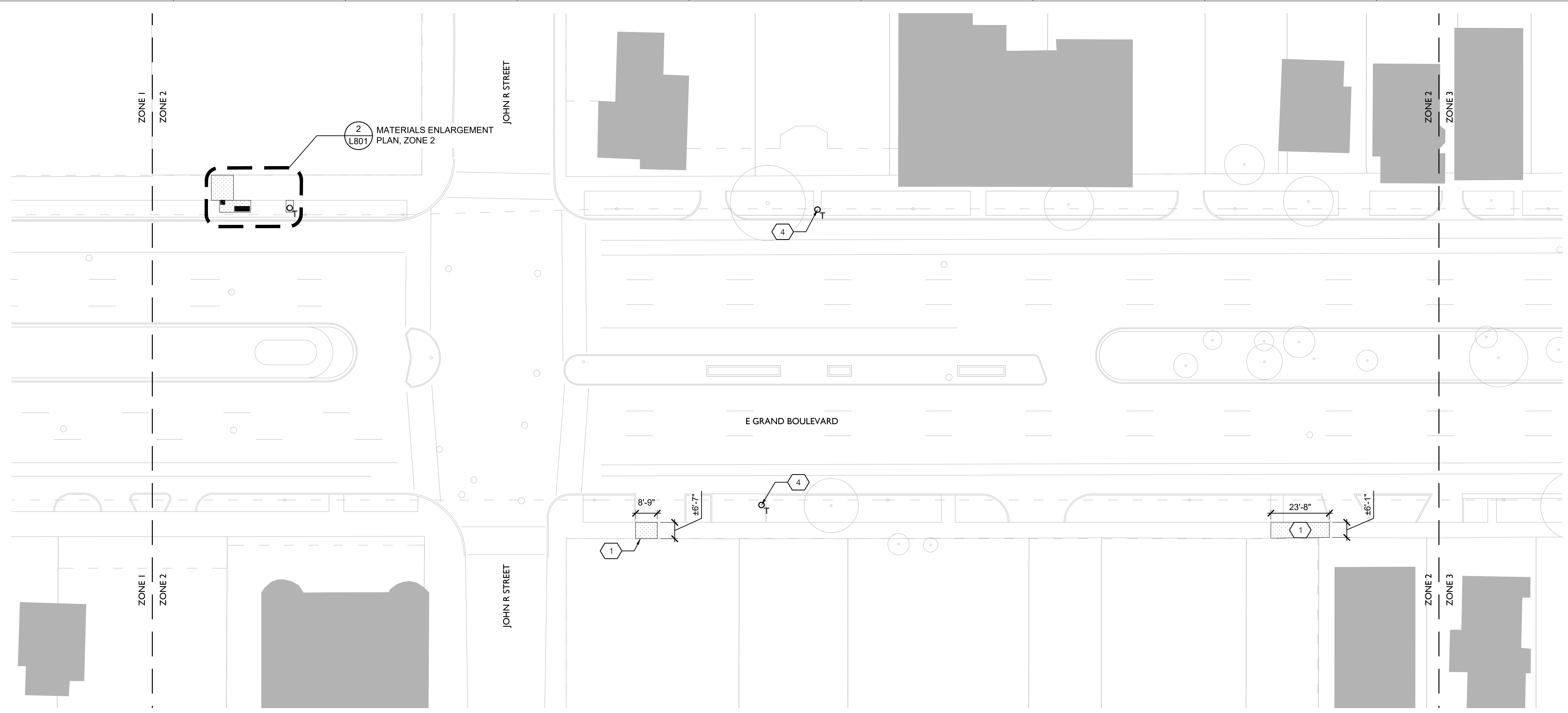

**1 MATERIALS PLAN - ZONE 2**  
Scale: 1"=20'-0"

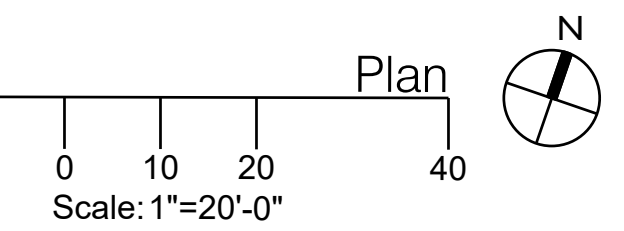

**STATUS:**  
100% CONSTRUCTION DOCUMENTS

**DATE:**  
21 SEPTEMBER 2022

**REVISION**  
NO. DESCRIPTION DATE

NO.	DESCRIPTION	DATE

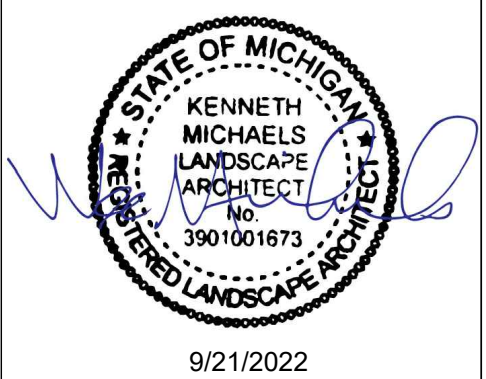

SMM Project No:  
21014

Sheet No:  
**MATERIALS PLAN  
ZONE 2**

Sheet No:  
**L202**

**LEGEND**

<b>1</b> LIMIT OF WORK	<b>2</b> NEW CONCRETE SIDEWALK, SEE 1/L900	<b>4</b> TRASH CANS, SEE 3/L910	<b>7</b> BENCH SWING, SEE 1/L911	<b>10</b> TOUCH UP EXISTING CROSSWALKS, BY CITY
<b>6</b> EXISTING TREES TO REMAIN AND BE PROTECTED	<b>2</b> BENCHES, SEE 2/L910	<b>5</b> VERTICAL STORYTELLING, SEE 1/L912	<b>8</b> SOLAR-POWERED CHARGING STATION, SEE 2/L911	<b>11</b> ARTISTIC CROSSWALKS, SEE 2/L900
<b>11</b> LOW	<b>3</b> BIKE RACKS, SEE 1/L910	<b>6</b> PLANTERS, SEE L250	<b>9</b> ART MURAL AT MEDIAN, SEE 3/L900	

**NOTES**

1. MAINTAIN MAX 4.5% SLOPE AND 2% CROSS SLOPE ACROSS ALL SIDEWALKS.
2. CONTRACTOR TO VERIFY ALL DIMENSIONS IN FIELD.
3. SEE L250 FOR SITE FURNISHINGS SCHEDULE.
4. SEE L900 SERIES FOR DETAILS.

**EAST GRAND BOULEVARD  
STREETSCAPE TRANSFORMATION**  
E GRAND BLVD, DETROIT

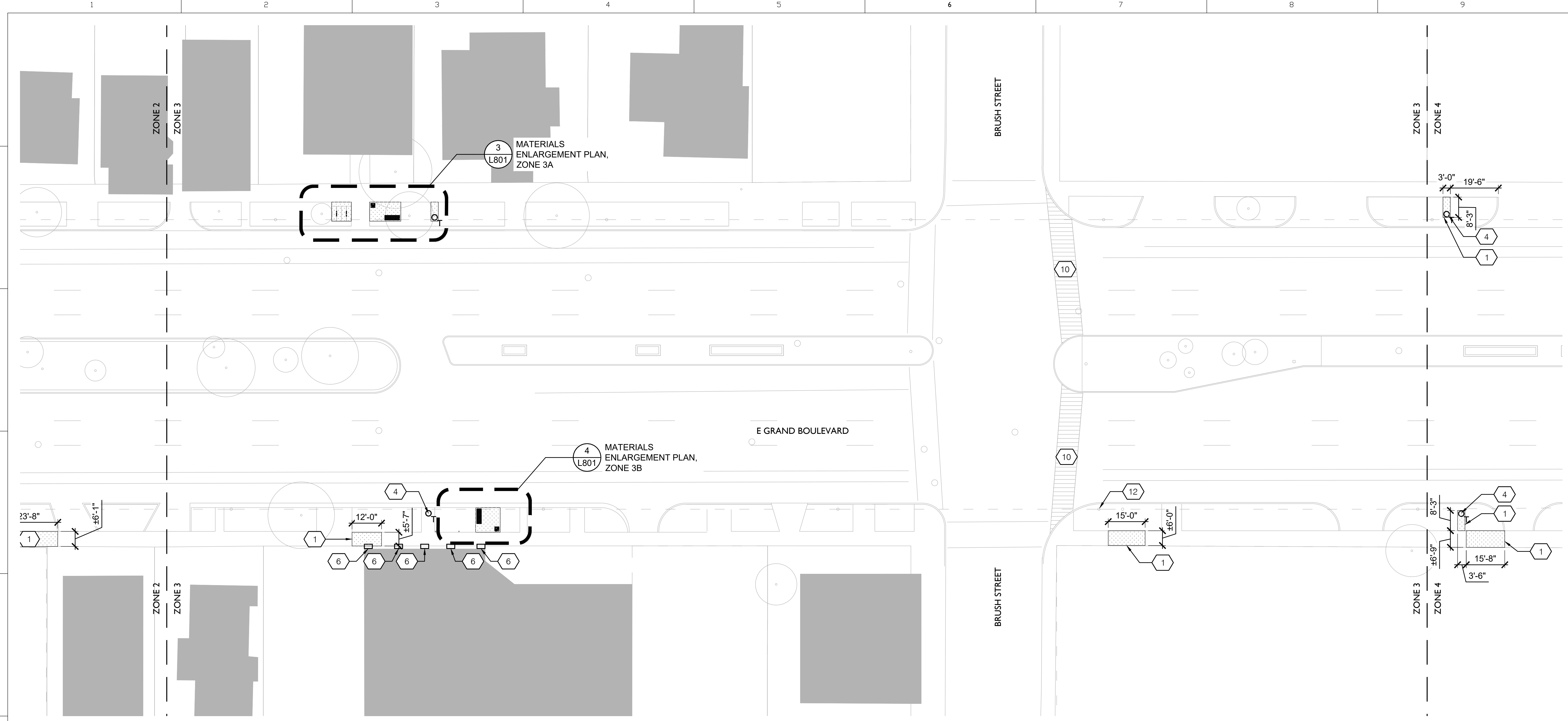

**1** MATERIALS PLAN - ZONE 3  
Scale: 1"=20'-0"

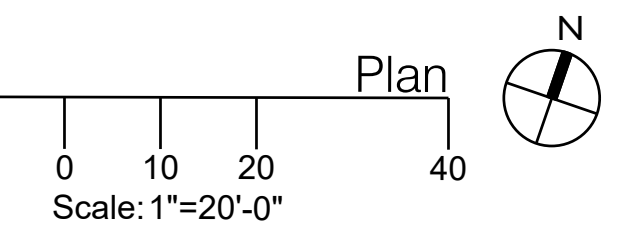

**LEGEND**

- LOW** LIMIT OF WORK
- EXISTING TREES TO REMAIN AND BE PROTECTED
- NEW CONCRETE SIDEWALK, SEE 1/L900
- BENCHES, SEE 2/L910
- BIKE RACKS, SEE 1/L910
- TRASH CANS, SEE 3/L910
- VERTICAL STORYTELLING, SEE 1/L912
- PLANTERS, SEE L250
- BENCH SWING, SEE 1/L911
- SOLAR-POWERED CHARGING STATION, SEE 2/L911
- ART MURAL AT MEDIAN, SEE 3/L900
- TOUCH UP EXISTING CROSSWALKS, BY CITY
- ARTISTIC CROSSWALKS, SEE 2/L900

**NOTES**

1. MAINTAIN MAX 4.5% SLOPE AND 2% CROSS SLOPE ACROSS ALL SIDEWALKS.
2. CONTRACTOR TO VERIFY ALL DIMENSIONS IN FIELD.
3. SEE L250 FOR SITE FURNISHINGS SCHEDULE.
4. SEE L900 SERIES FOR DETAILS.

**STATUS:**  
100% CONSTRUCTION DOCUMENTS

**DATE:**  
21 SEPTEMBER 2022

**REVISION**

NO.	DESCRIPTION	DATE

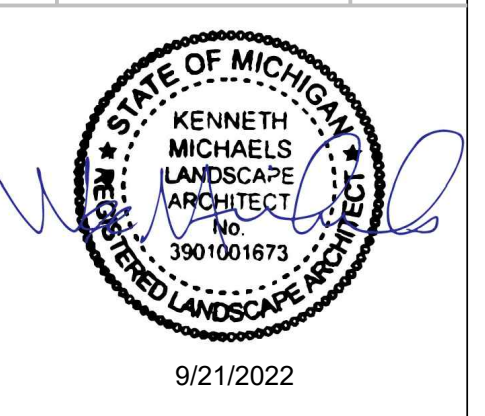

SMM Project No:  
21014

Sheet No:  
**MATERIALS PLAN  
ZONE 3**

Sheet No:  
**L203**



EAST GRAND BOULEVARD  
STREETSCAPE TRANSFORMATION  
E GRAND BLVD, DETROIT

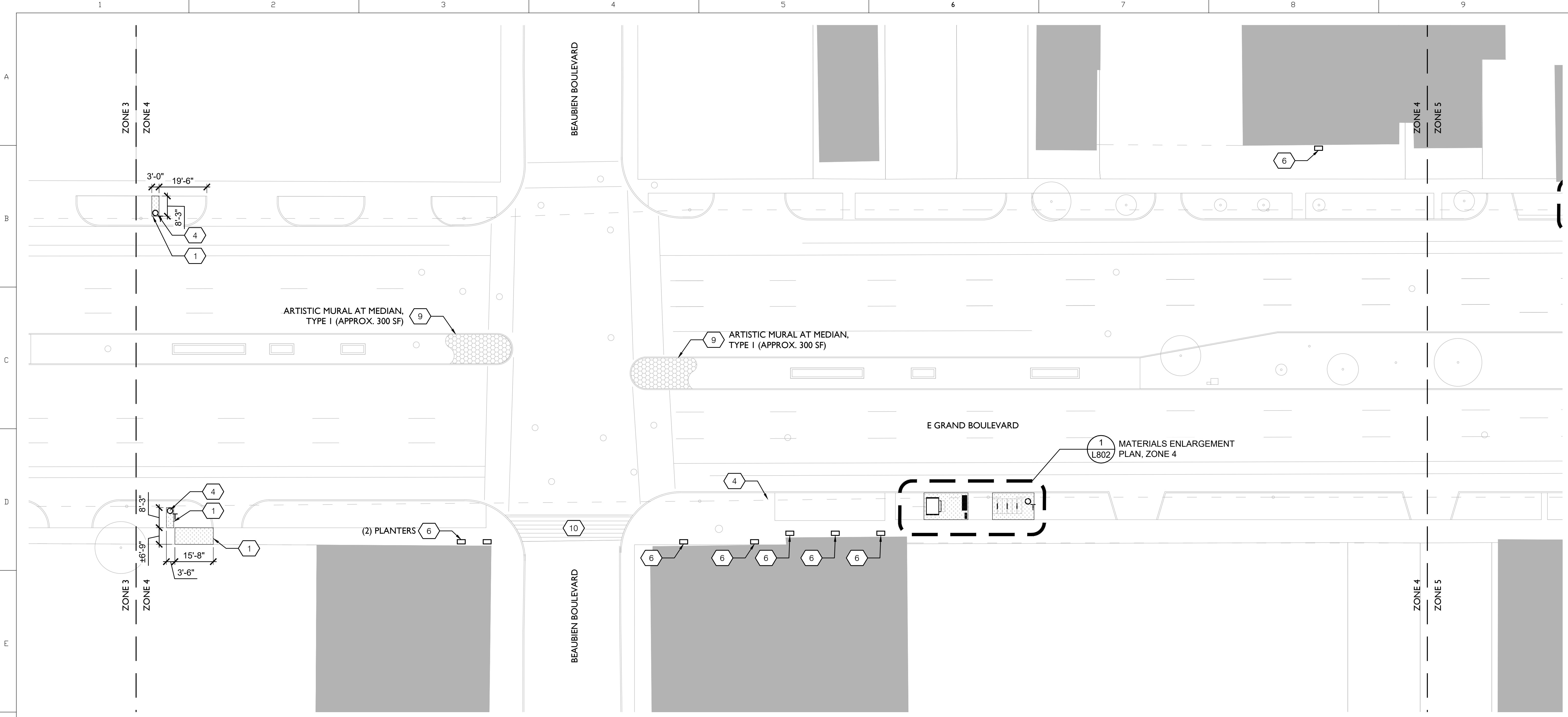

**1** MATERIALS PLAN - ZONE 4  
Scale: 1"=20'-0"

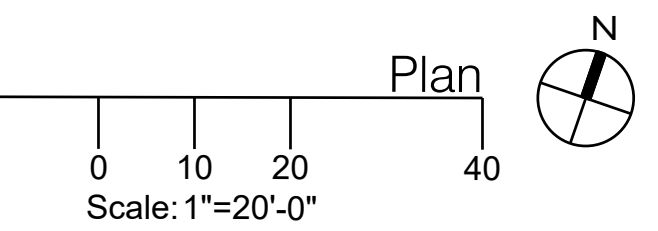

**STATUS:**  
100% CONSTRUCTION DOCUMENTS

**DATE:**  
21 SEPTEMBER 2022

REVISION		
NO.	DESCRIPTION	DATE



**LEGEND**

<b>1</b> LIMIT OF WORK	<b>4</b> TRASH CANS, SEE 3/L910	<b>7</b> BENCH SWING, SEE 1/L911	<b>10</b> TOUCH UP EXISTING CROSSWALKS, BY CITY
<b>2</b> EXISTING TREES TO REMAIN AND BE PROTECTED	<b>5</b> VERTICAL STORYTELLING, SEE 1/L912	<b>8</b> SOLAR-POWERED CHARGING STATION, SEE 2/L911	<b>11</b> ARTISTIC CROSSWALKS, SEE 2/L900
<b>3</b> BIKE RACKS, SEE 1/L910	<b>6</b> PLANTERS, SEE L250	<b>9</b> ART MURAL AT MEDIAN, SEE 3/L900	
<b>1</b> NEW CONCRETE SIDEWALK, SEE 1/L900			

**NOTES**

1. MAINTAIN MAX 4.5% SLOPE AND 2% CROSS SLOPE ACROSS ALL SIDEWALKS.
2. CONTRACTOR TO VERIFY ALL DIMENSIONS IN FIELD.
3. SEE L250 FOR SITE FURNISHINGS SCHEDULE.
4. SEE L900 SERIES FOR DETAILS.

SMM Project No:  
21014

Sheet No:  
**MATERIALS PLAN  
ZONE 4**

Sheet No:  
**L204**

**EAST GRAND BOULEVARD  
STREETSCAPE TRANSFORMATION**  
E GRAND BLVD, DETROIT

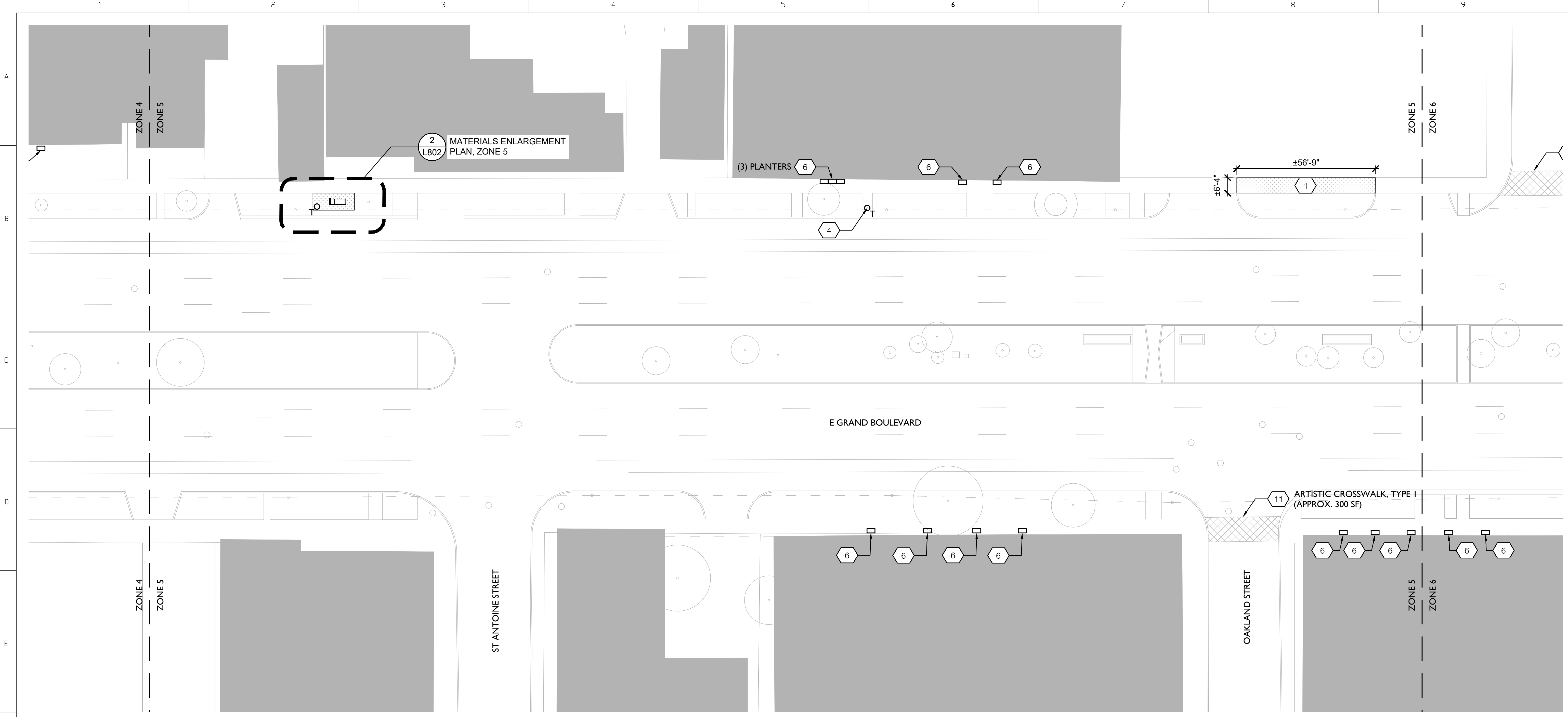

**1** MATERIALS PLAN - ZONE 5  
Scale: 1"=20'-0"

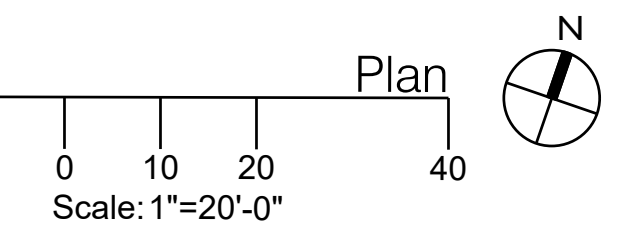

**LEGEND**

	LOW LIMIT OF WORK		NEW CONCRETE SIDEWALK, SEE 1/L900		TRASH CANS, SEE 3/L910		BENCH SWING, SEE 1/L911		TOUCH UP EXISTING CROSSWALKS, BY CITY
	EXISTING TREES TO REMAIN AND BE PROTECTED		BENCHES, SEE 2/L910		VERTICAL STORYTELLING, SEE 1/L912		SOLAR-POWERED CHARGING STATION, SEE 2/L911		ARTISTIC CROSSWALKS, SEE 2/L900
			BIKE RACKS, SEE 1/L910		PLANTERS, SEE L250		ART MURAL AT MEDIAN, SEE 3/L900		

**NOTES**

1. MAINTAIN MAX 4.5% SLOPE AND 2% CROSS SLOPE ACROSS ALL SIDEWALKS.
2. CONTRACTOR TO VERIFY ALL DIMENSIONS IN FIELD.
3. SEE L250 FOR SITE FURNISHINGS SCHEDULE.
4. SEE L900 SERIES FOR DETAILS.

**STATUS:**  
100% CONSTRUCTION DOCUMENTS

**DATE:**  
21 SEPTEMBER 2022

REVISION NO.	DESCRIPTION	DATE



SMM Project No:  
21014

Sheet No:  
**MATERIALS PLAN  
ZONE 5**

Sheet No:  
**L205**



**EAST GRAND BOULEVARD  
STREETSCAPE TRANSFORMATION  
E GRAND BLVD, DETROIT**

**STATUS:**  
100% CONSTRUCTION DOCUMENTS

**DATE:**  
21 SEPTEMBER 2022

**REVISION**  
NO. | DESCRIPTION | DATE

NO.	DESCRIPTION	DATE



SMM Project No:  
21014

Sheet No:  
**MATERIALS PLAN  
ZONE 6**

Sheet No:  
**L206**

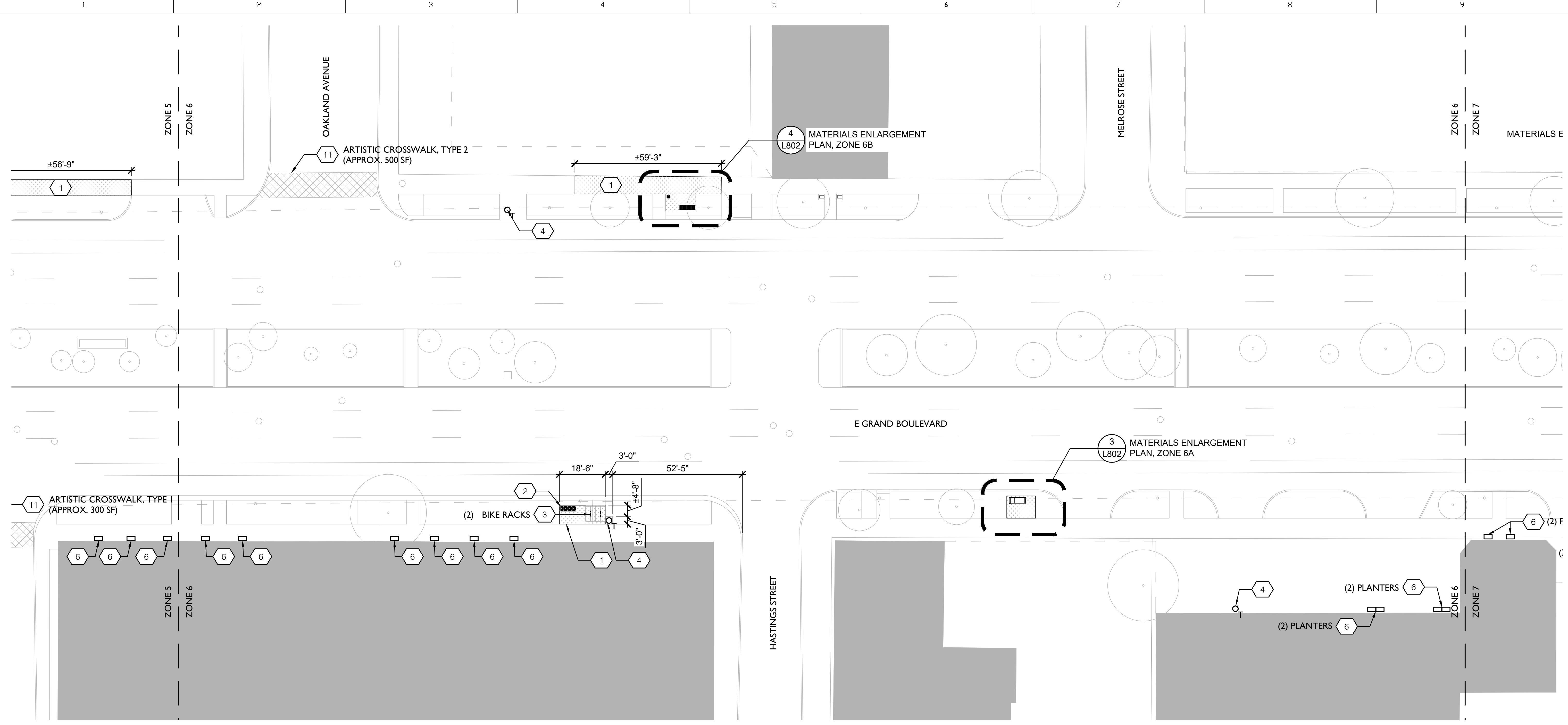

**1 MATERIALS PLAN - ZONE 6**  
Scale: 1"=20'-0"

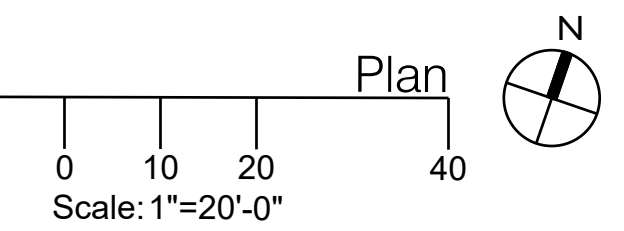

**LEGEND**

<b>LOW</b> LIMIT OF WORK	NEW CONCRETE SIDEWALK, SEE 1/L900	TRASH CANS, SEE 3/L910	BENCH SWING, SEE 1/L911	TOUCH UP EXISTING CROSSWALKS, BY CITY
EXISTING TREES TO REMAIN AND BE PROTECTED	BENCHES, SEE 2/L910	VERTICAL STORYTELLING, SEE 1/L912	SOLAR-POWERED CHARGING STATION, SEE 2/L911	ARTISTIC CROSSWALKS, SEE 2/L900
	BIKE RACKS, SEE 1/L910	PLANTERS, SEE L250	ART MURAL AT MEDIAN, SEE 3/L900	

**NOTES**

1. MAINTAIN MAX 4.5% SLOPE AND 2% CROSS SLOPE ACROSS ALL SIDEWALKS.
2. CONTRACTOR TO VERIFY ALL DIMENSIONS IN FIELD.
3. SEE L250 FOR SITE FURNISHINGS SCHEDULE.
4. SEE L900 SERIES FOR DETAILS.

**EAST GRAND BOULEVARD  
STREETSCAPE TRANSFORMATION**  
E GRAND BLVD, DETROIT

**STATUS:**  
100% CONSTRUCTION DOCUMENTS

**DATE:**  
21 SEPTEMBER 2022

REVISION NO.	DESCRIPTION	DATE

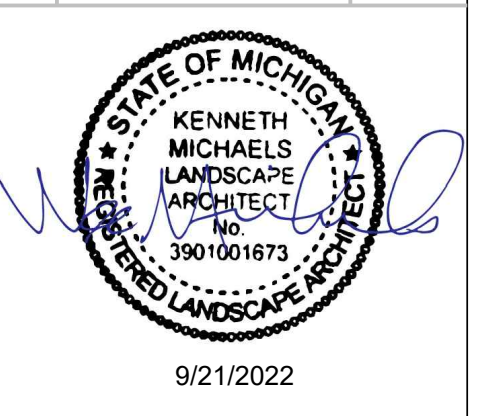

SMM Project No:  
21014

Sheet No:  
**MATERIALS PLAN  
ZONE 7**

Sheet No:  
**L207**

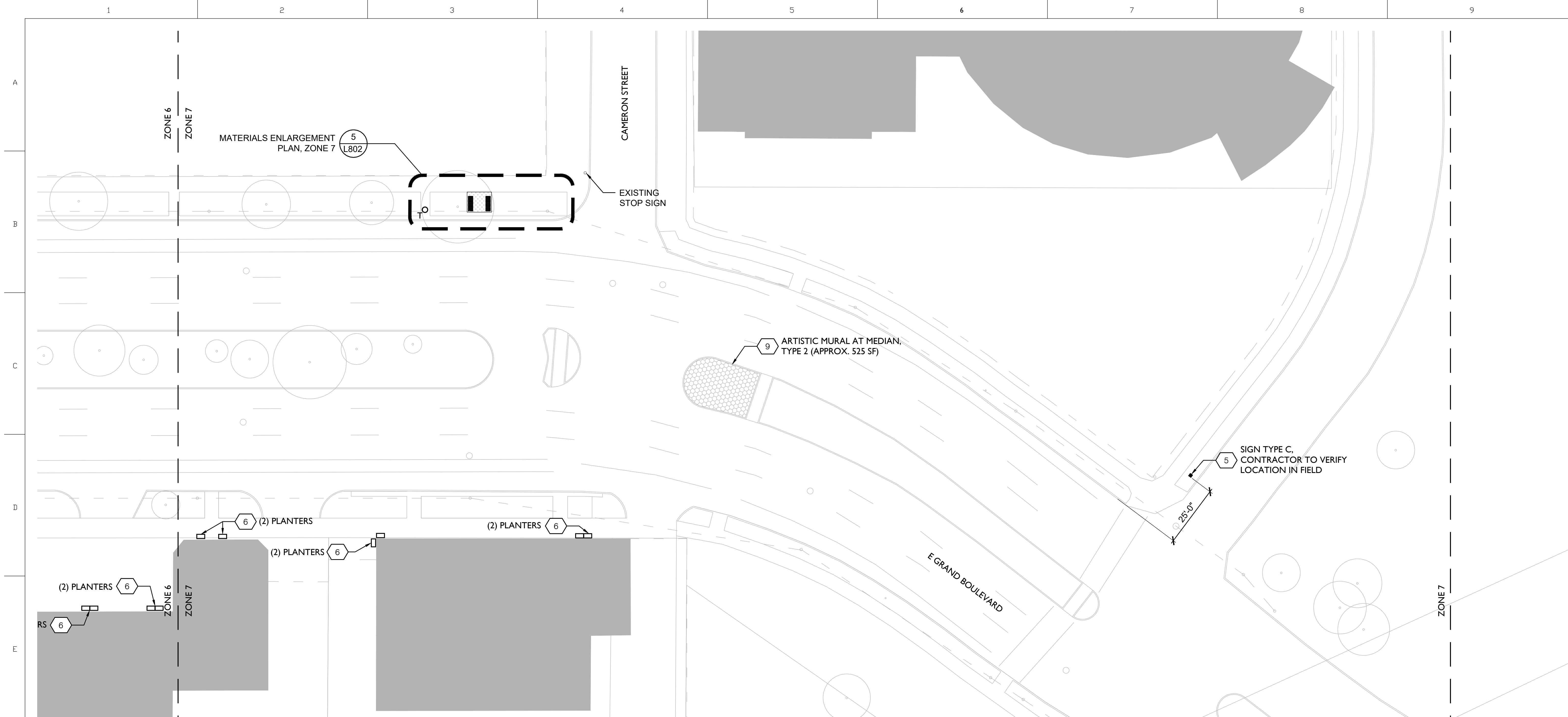

**1 MATERIALS PLAN - ZONE 7**  
Scale: 1"=20'-0"

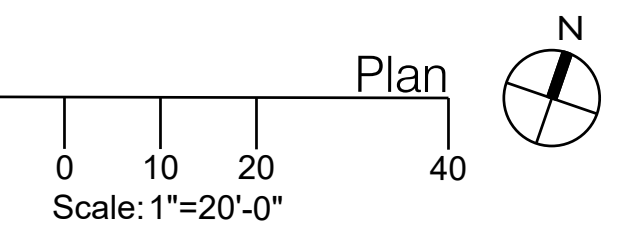

**LEGEND**

	LOW LIMIT OF WORK		NEW CONCRETE SIDEWALK, SEE 1/L900		TRASH CANS, SEE 3/L910		BENCH SWING, SEE 1/L911		TOUCH UP EXISTING CROSSWALKS, BY CITY
	EXISTING TREES TO REMAIN AND BE PROTECTED		BENCHES, SEE 2/L910		VERTICAL STORYTELLING, SEE 1/L912		SOLAR-POWERED CHARGING STATION, SEE 2/L911		ARTISTIC CROSSWALKS, SEE 2/L900
	BIKE RACKS, SEE 1/L910		PLANTERS, SEE L250		ART MURAL AT MEDIAN, SEE 3/L900				

**NOTES**

1. MAINTAIN MAX 4.5% SLOPE AND 2% CROSS SLOPE ACROSS ALL SIDEWALKS.
2. CONTRACTOR TO VERIFY ALL DIMENSIONS IN FIELD.
3. SEE L250 FOR SITE FURNISHINGS SCHEDULE.
4. SEE L900 SERIES FOR DETAILS.



A  
B  
C  
D  
E  
F  
G  
H

SITE FURNISHINGS SCHEDULE (12 93 00)								
SYMBOL	PRODUCT	MANUFACTURER	MATERIAL	QTY TO BE INSTALLED	QTY TO BE STORED BY OWNER	SIZE	COLOR	NOTES
■	BENCH	ANOVA (ITEM #: TAN3483MR)	ALUMINUM & STEEL	8	4	35"H x 22"W x 72"L	BLACK	BACKED W/ ARMRESTS; SURFACE MOUNT
1 3	BIKE RACK	ANOVA (ITEM #: CIRCLEBR2)	STAINLESS STEEL FINISH	9	3	32"H x 6"W x 36"L	N/A	SURFACE MOUNT
Q <sub>T</sub> 4	TRASH CAN	VICTOR STANLEY (MODEL: ES-342)	RECYCLED STEEL	15	-	36 GAL.	BLACK	SURFACE MOUNT
□ 6	URBAN RECTANGLE PLANTERS	EARTH PLANTER (SKU: EPUR40-)	LLDPE, LINEAR LOW-DENSITY POLYETHYLENE	45	-	40"L x 22"W x 24"H	BLACKSTONE	PROVIDED BY OTHERS
7	BENCH SWING	STUDIO 431 (LANDSCAPE FORMS)	COMMERCIAL GRADE STEEL, POWDERCOAT FINISH	1	-	103.89"H x 60.60"W x 85"L	COLOR TBD BY LANDSCAPE ARCHITECT	MANUFACTURER TO PROVIDE ENGINEERING FOR CONCRETE FOUNDATION/FOOTINGS
8	SMART SOLAR BENCH	EnGoPlanet	WOODEN BENCH AND STRIP-LIKE STEEL	2	1	80"L x 27"W x 12 5/8"H	DARK GRAY	OWNER TO PROVIDE ARTWORK FOR SIGNAGE
VERTICAL STORYTELLING SIGNAGE (12 93 00)								
	SIGN TYPE A	BANNER SIGN COMANY	SEE L912	1	-	SEE L912	SEE L912	SEE L912
	SIGN TYPE B	BANNER SIGN COMANY	SEE L912	1	-	SEE L912	SEE L912	SEE L912
	SIGN TYPE C	BANNER SIGN COMANY	SEE L912	2	-	SEE L912	SEE L912	SEE L912
	SIGN TYPE D	BANNER SIGN COMANY	SEE L912	3	-	SEE L912	SEE L912	SEE L912

**spackman  
mossop  
michaels**  
440 Burroughs Street  
Suite 696  
Detroit | MI | 48202  
T: 313.720.1055  
LANDSCAPE ARCHITECTS

**EAST GRAND BOULEVARD  
STREETSCAPE TRANSFORMATION**  
E GRAND BLVD, DETROIT

**STATUS:**  
100% CONSTRUCTION DOCUMENTS

**DATE:**  
21 SEPTEMBER 2022

**REVISION**  
NO. DESCRIPTION DATE

NO.	DESCRIPTION	DATE



SMM Project No:  
21014

Sheet No:  
**SITE FURNISHINGS  
SCHEDULE**

Sheet No:  
**L250**

1

2

3

4

5

6

7

8

9

**EAST GRAND BOULEVARD  
STREETSCAPE TRANSFORMATION**  
E GRAND BLVD, DETROIT

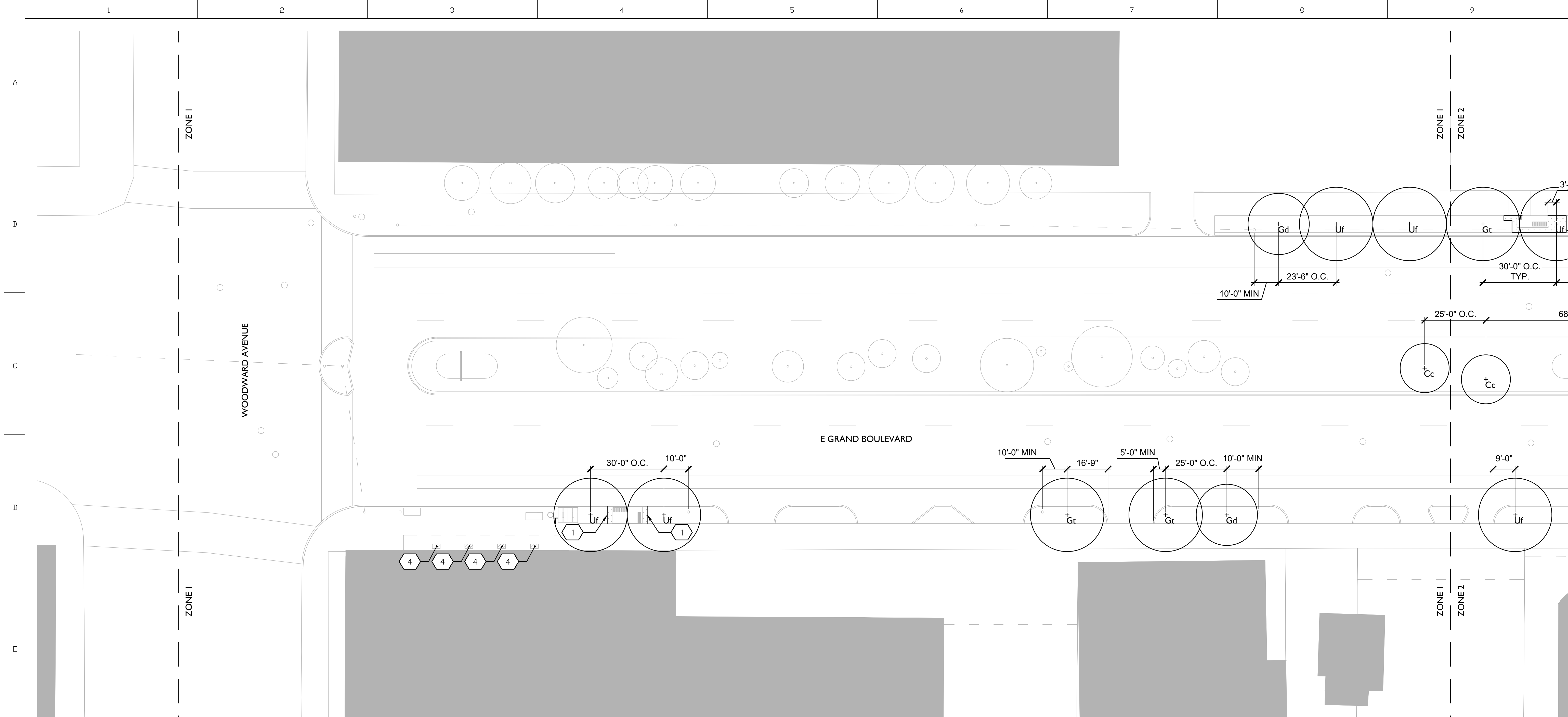

**1** PLANTING PLAN - ZONE 1  
Scale: 1"=20'-0"

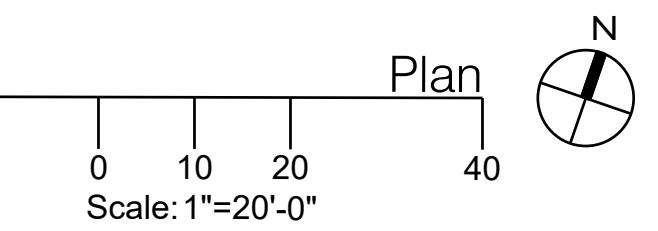

**STATUS:**  
100% CONSTRUCTION DOCUMENTS

**DATE:**  
21 SEPTEMBER 2022

REVISION NO.	DESCRIPTION	DATE



SMM Project No:  
21014

Sheet No:

**PLANTING PLAN  
ZONE I**

Sheet No:  
**L501**

LEGEND	
	LOW LIMIT OF WORK
	EXISTING TREES TO REMAIN AND BE PROTECTED
	PROPOSED TREE PLANTING, BY OTHERS
	REPAIR EXISTING SOD AS NEEDED, SEE 3/L591
	PLANTING BED TYPE 1, SEE 1/L590
	PLANTING BED TYPE 2, SEE L550
	PLANTING IN PLANTERS, BY OTHERS

- PLANTING NOTES**
- SEE L550 FOR PLANT SCHEDULE
  - SEE L590-L591 FOR TYPICAL PLANTING DETAILS.
  - CONTRACTOR SHALL RENOVATE EXISTING TURF DAMAGED DURING CONSTRUCTION (32 92 00).
  - LANDSCAPE ARCHITECT TO CONFIRM LOCATION OF ALL PLANT MATERIALS PRIOR TO INSTALLATION.



**EAST GRAND BOULEVARD  
STREETSCAPE TRANSFORMATION**  
E GRAND BLVD, DETROIT

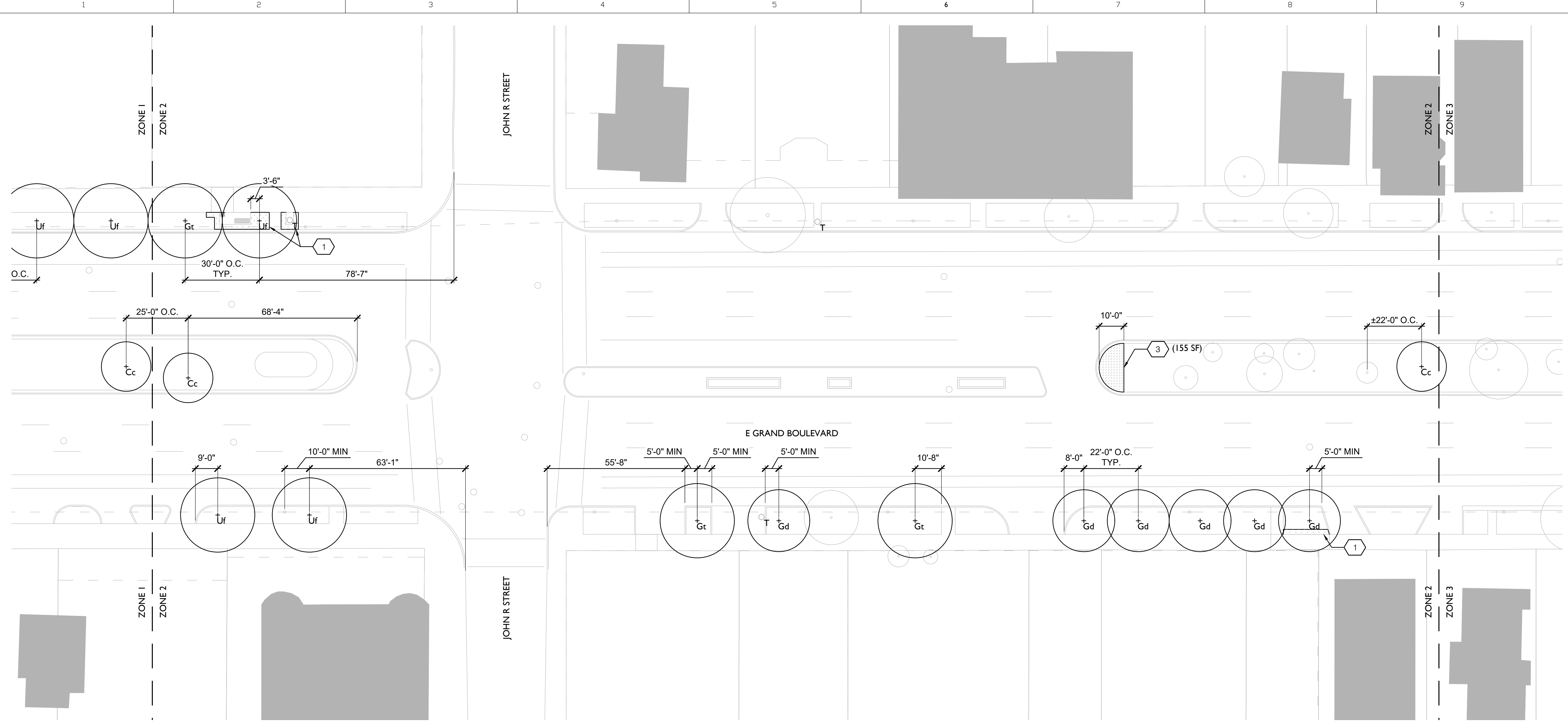

**1** PLANTING PLAN - ZONE 2  
Scale: 1"=20'-0"

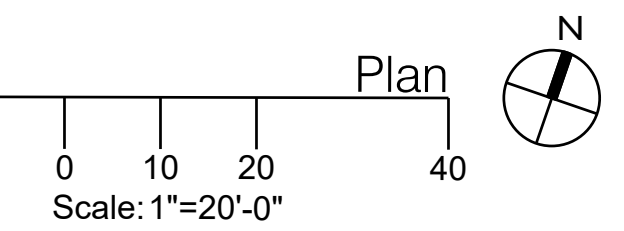

LEGEND			
	LOW LIMIT OF WORK		REPAIR EXISTING SOD AS NEEDED, SEE 3/L591
	EXISTING TREES TO REMAIN AND BE PROTECTED		PLANTING BED TYPE 1, SEE 1/L590
	PROPOSED TREE PLANTING, BY OTHERS		PLANTING BED TYPE 2, SEE L550
			PLANTING IN PLANTERS, BY OTHERS

- PLANTING NOTES**
- SEE L550 FOR PLANT SCHEDULE
  - SEE L590-L591 FOR TYPICAL PLANTING DETAILS.
  - CONTRACTOR SHALL RENOVATE EXISTING TURF DAMAGED DURING CONSTRUCTION (32 92 00).
  - LANDSCAPE ARCHITECT TO CONFIRM LOCATION OF ALL PLANT MATERIALS PRIOR TO INSTALLATION.

**STATUS:**  
100% CONSTRUCTION DOCUMENTS

**DATE:**  
21 SEPTEMBER 2022

REVISION		
NO.	DESCRIPTION	DATE

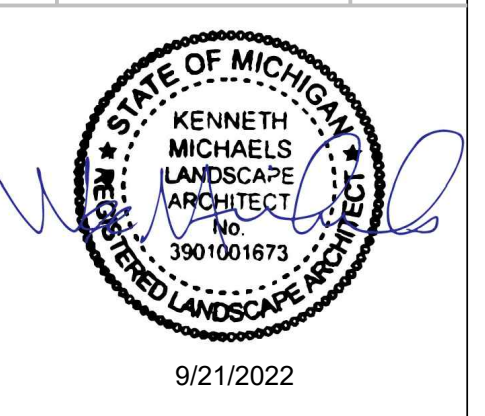

SMM Project No:  
21014

Sheet No:  
**PLANTING PLAN  
ZONE 2**

Sheet No:  
**L502**

**EAST GRAND BOULEVARD  
STREETSCAPE TRANSFORMATION**  
E GRAND BLVD, DETROIT

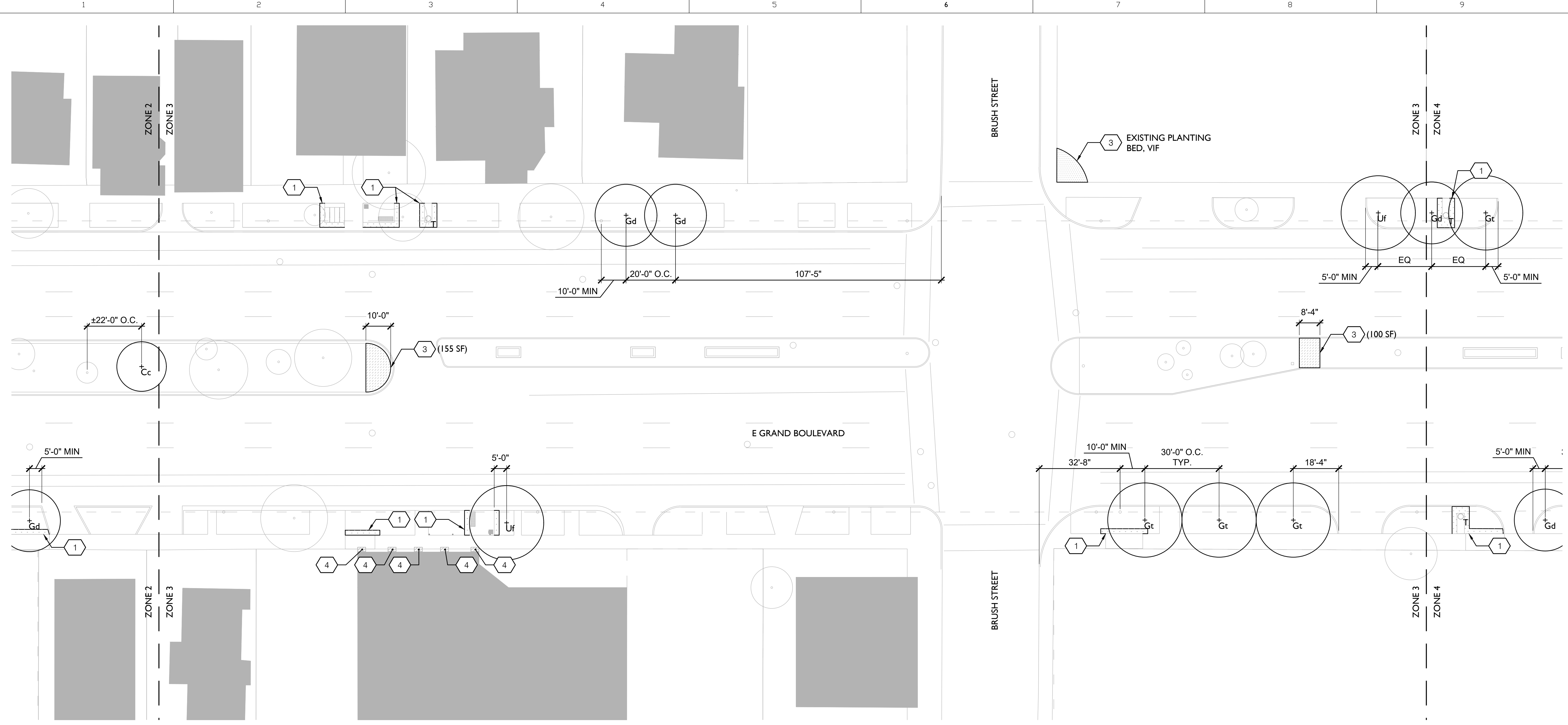

**1** PLANTING PLAN - ZONE 3  
Scale: 1"=20'-0"

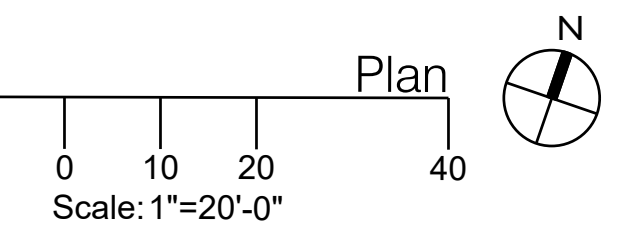

**LEGEND**

	LOW LIMIT OF WORK		REPAIR EXISTING SOD AS NEEDED, SEE 3/L591		PLANTING IN PLANTERS, BY OTHERS
	EXISTING TREES TO REMAIN AND BE PROTECTED		PLANTING BED TYPE 1, SEE 1/L590		
	PROPOSED TREE PLANTING, BY OTHERS		PLANTING BED TYPE 2, SEE L550		

**PLANTING NOTES**

1. SEE L550 FOR PLANT SCHEDULE
2. SEE L590-L591 FOR TYPICAL PLANTING DETAILS.
3. CONTRACTOR SHALL RENOVATE EXISTING TURF DAMAGED DURING CONSTRUCTION (32 92 00).
4. LANDSCAPE ARCHITECT TO CONFIRM LOCATION OF ALL PLANT MATERIALS PRIOR TO INSTALLATION.

**STATUS:**  
100% CONSTRUCTION DOCUMENTS

**DATE:**  
21 SEPTEMBER 2022

REVISION NO.	DESCRIPTION	DATE

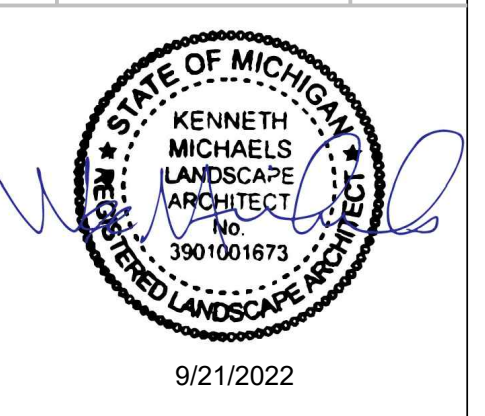

SMM Project No:  
21014

Sheet No:  
**PLANTING PLAN  
ZONE 3**

Sheet No:  
**L503**



**STATUS:**  
100% CONSTRUCTION DOCUMENTS

**DATE:**  
21 SEPTEMBER 2022

**REVISION**  
NO. | DESCRIPTION | DATE

NO.	DESCRIPTION	DATE



SMM Project No:  
21014

Sheet No:  
**PLANTING PLAN  
ZONE 4**

Sheet No:  
**L504**

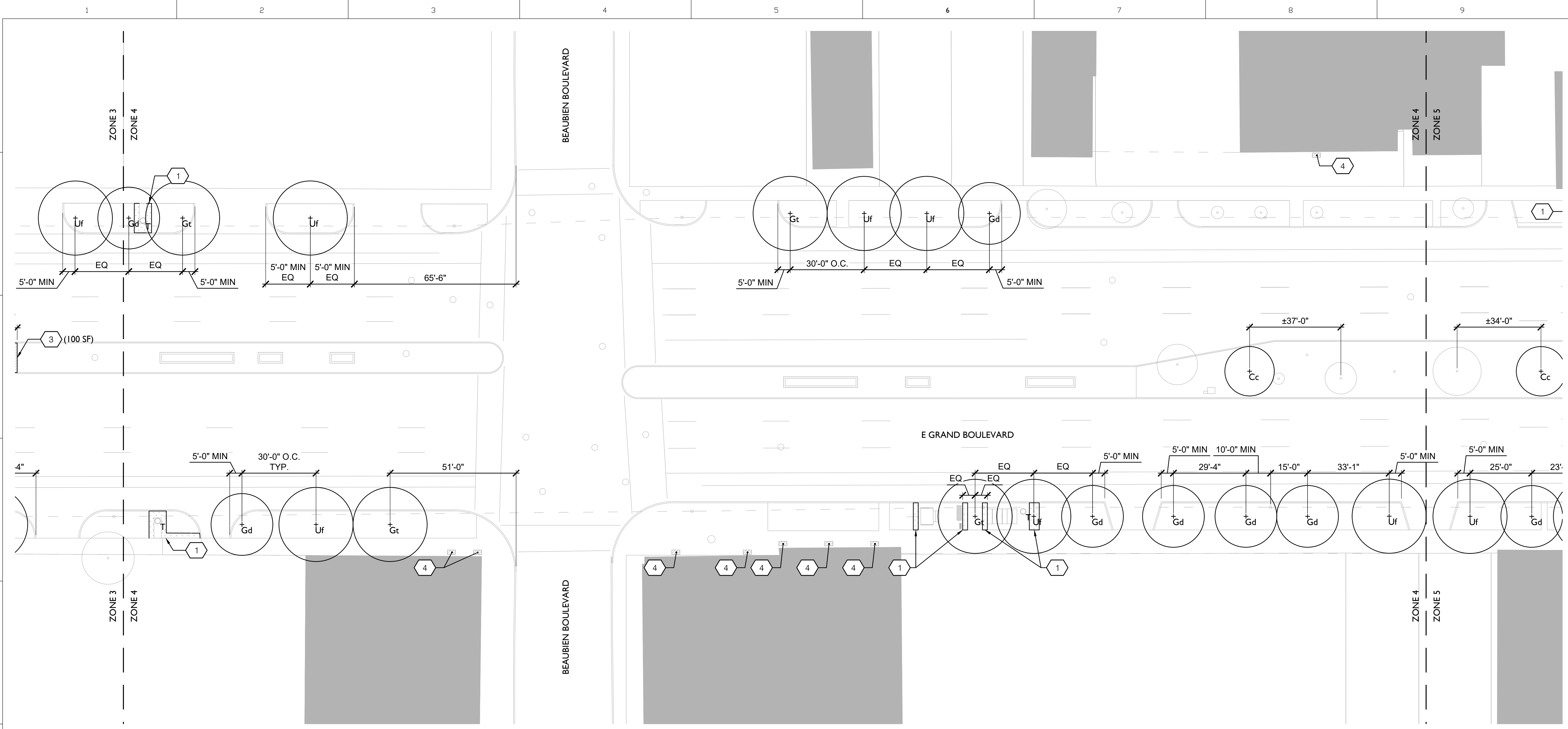

**1** PLANTING PLAN - ZONE 4  
Scale: 1"=20'-0"

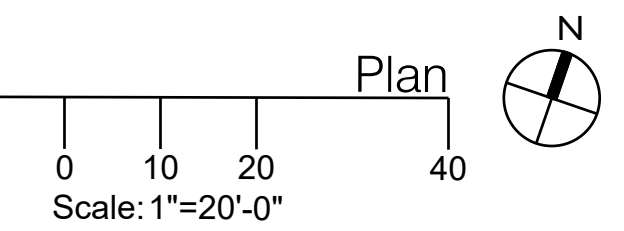

**LEGEND**

	LOW	LIMIT OF WORK		REPAIR EXISTING SOD AS NEEDED, SEE 3/L591		PLANTING IN PLANTERS, BY OTHERS
		EXISTING TREES TO REMAIN AND BE PROTECTED		PLANTING BED TYPE 1, SEE 1/L590		
		PROPOSED TREE PLANTING, BY OTHERS		PLANTING BED TYPE 2, SEE L550		

- PLANTING NOTES**
- SEE L550 FOR PLANT SCHEDULE
  - SEE L590-L591 FOR TYPICAL PLANTING DETAILS.
  - CONTRACTOR SHALL RENOVATE EXISTING TURF DAMAGED DURING CONSTRUCTION (32 92 00).
  - LANDSCAPE ARCHITECT TO CONFIRM LOCATION OF ALL PLANT MATERIALS PRIOR TO INSTALLATION.

**EAST GRAND BOULEVARD  
STREETSCAPE TRANSFORMATION**  
E GRAND BLVD, DETROIT

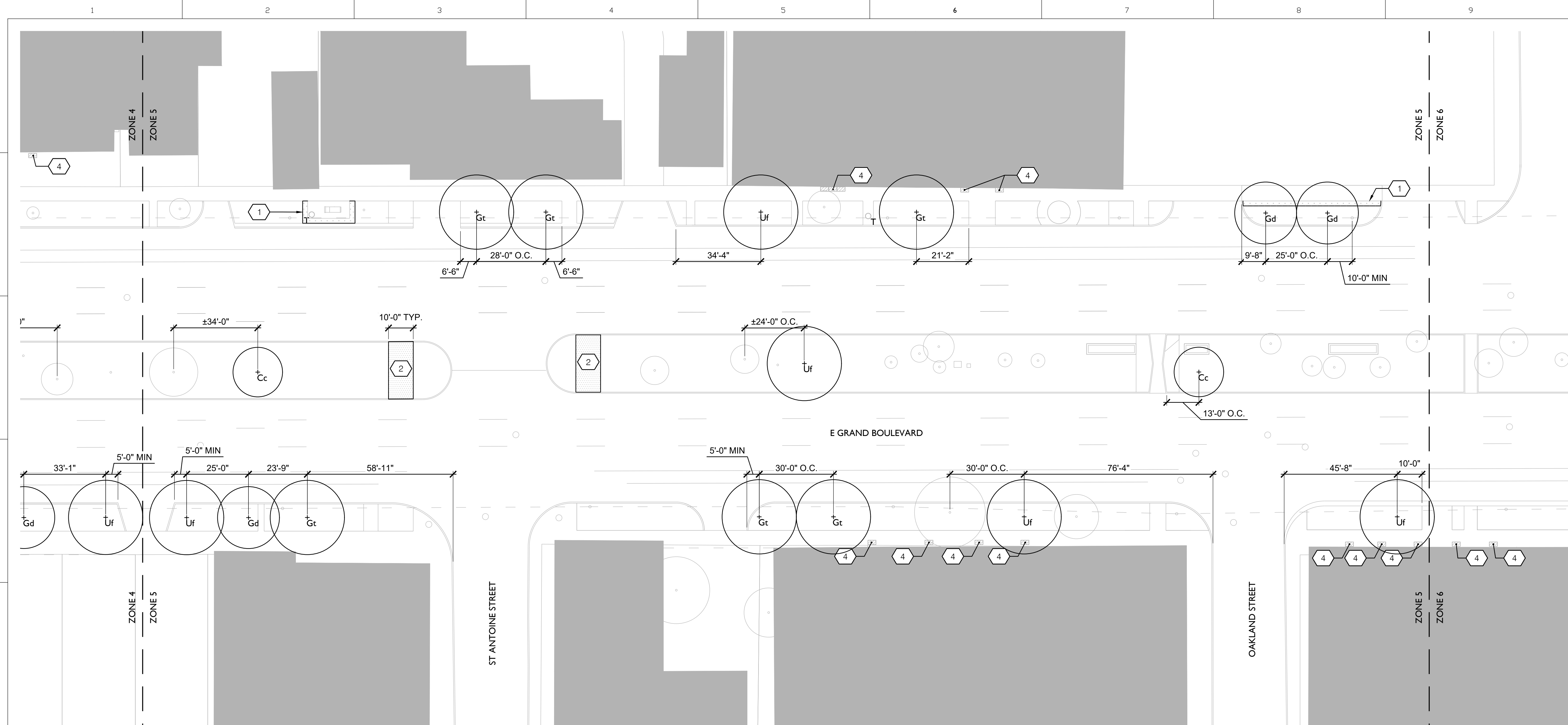

**1 PLANTING PLAN - ZONE 5**  
Scale: 1"=20'-0"

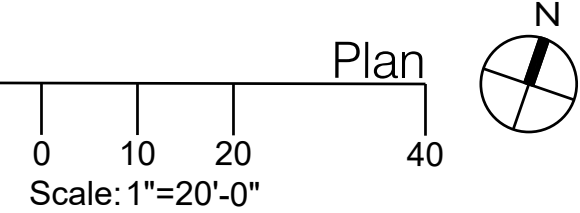

**STATUS:**  
100% CONSTRUCTION DOCUMENTS

**DATE:**  
21 SEPTEMBER 2022

**REVISION**  
NO. DESCRIPTION DATE

NO.	DESCRIPTION	DATE

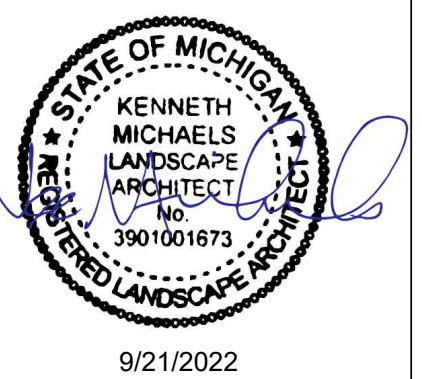

**LEGEND**

- |  |   |  |   |  |                                 |
|--|---|--|---|--|---------------------------------|
|  | LOW LIMIT OF WORK                         |  | REPAIR EXISTING SOD AS NEEDED, SEE 3/L591 |  | PLANTING IN PLANTERS, BY OTHERS |
|  | EXISTING TREES TO REMAIN AND BE PROTECTED |  | PLANTING BED TYPE 1, SEE 1/L590           |  |                                 |
|  | PROPOSED TREE PLANTING, BY OTHERS         |  | PLANTING BED TYPE 2, SEE L550             |  |                                 |

**PLANTING NOTES**

- SEE L550 FOR PLANT SCHEDULE
- SEE L590-L591 FOR TYPICAL PLANTING DETAILS.
- CONTRACTOR SHALL RENOVATE EXISTING TURF DAMAGED DURING CONSTRUCTION (32 92 00).
- LANDSCAPE ARCHITECT TO CONFIRM LOCATION OF ALL PLANT MATERIALS PRIOR TO INSTALLATION.

SMM Project No:  
21014

Sheet No:  
**PLANTING PLAN  
ZONE 5**

Sheet No:  
**L505**



**EAST GRAND BOULEVARD  
STREETSCAPE TRANSFORMATION**  
E GRAND BLVD, DETROIT

**STATUS:**  
100% CONSTRUCTION DOCUMENTS

**DATE:**  
21 SEPTEMBER 2022

**REVISION**

NO.	DESCRIPTION	DATE



SMM Project No:  
21014

Sheet No:  
**PLANTING PLAN  
ZONE 6**

Sheet No:  
**L506**

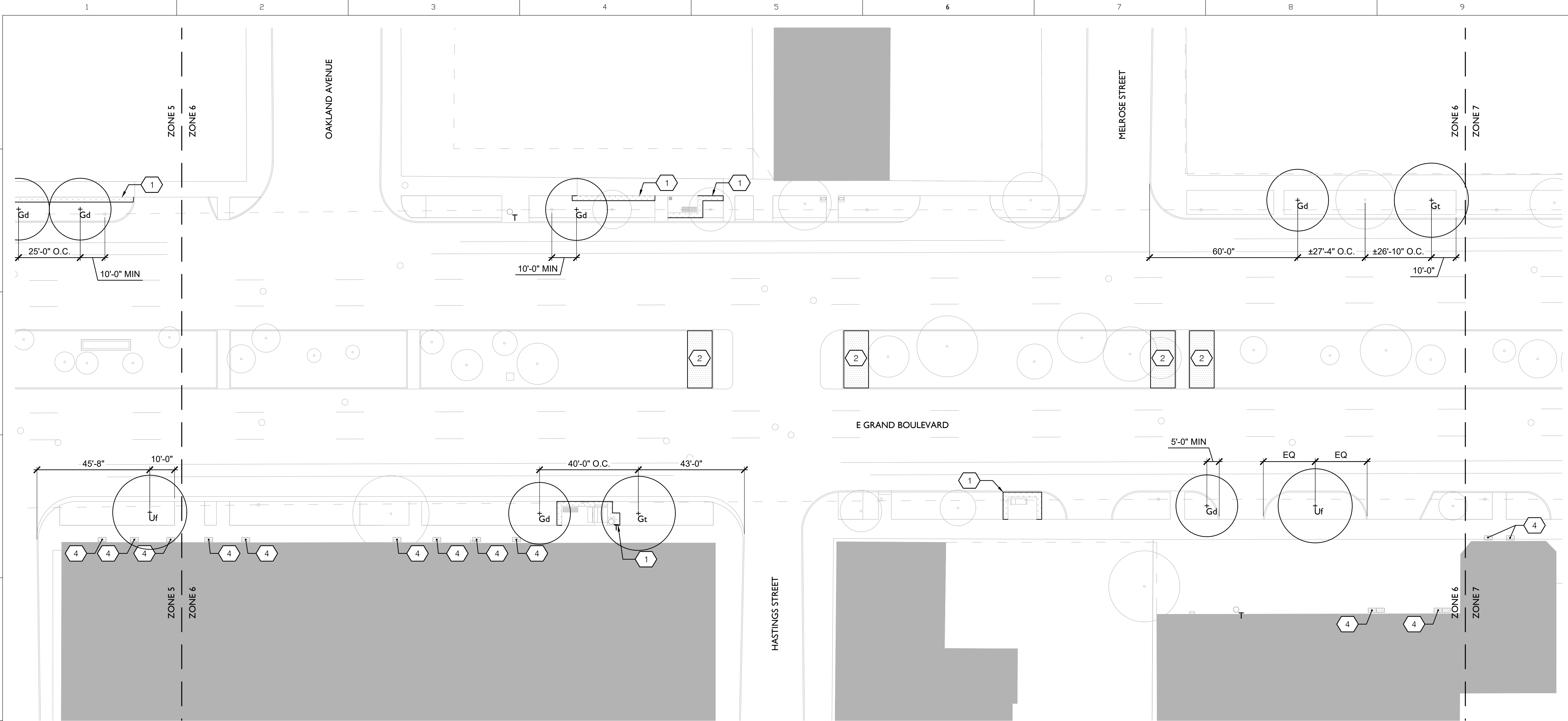

**1** PLANTING PLAN - ZONE 6  
Scale: 1"=20'-0"

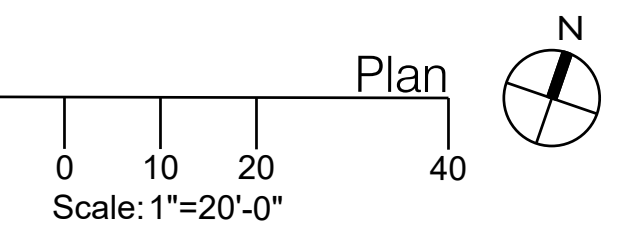

**LEGEND**

- |       |   |   |  |   |                                    |
|-------|---|---|--|---|------------------------------------|
| — LOW | LIMIT OF WORK                                   | 1 | REPAIR EXISTING SOD<br>AS NEEDED, SEE 3/L591 | 4 | PLANTING IN PLANTERS,<br>BY OTHERS |
| ○     | EXISTING TREES<br>TO REMAIN AND<br>BE PROTECTED | 2 | PLANTING BED<br>TYPE 1, SEE 1/L590           |   |                                    |
| ⊕     | PROPOSED TREE<br>PLANTING, BY OTHERS            | 3 | PLANTING BED<br>TYPE 2, SEE L550             |   |                                    |

**PLANTING NOTES**

- SEE L550 FOR PLANT SCHEDULE
- SEE L590-L591 FOR TYPICAL PLANTING DETAILS.
- CONTRACTOR SHALL RENOVATE EXISTING TURF DAMAGED DURING CONSTRUCTION (32 92 00).
- LANDSCAPE ARCHITECT TO CONFIRM LOCATION OF ALL PLANT MATERIALS PRIOR TO INSTALLATION.

**EAST GRAND BOULEVARD  
STREETSCAPE TRANSFORMATION**  
E GRAND BLVD, DETROIT

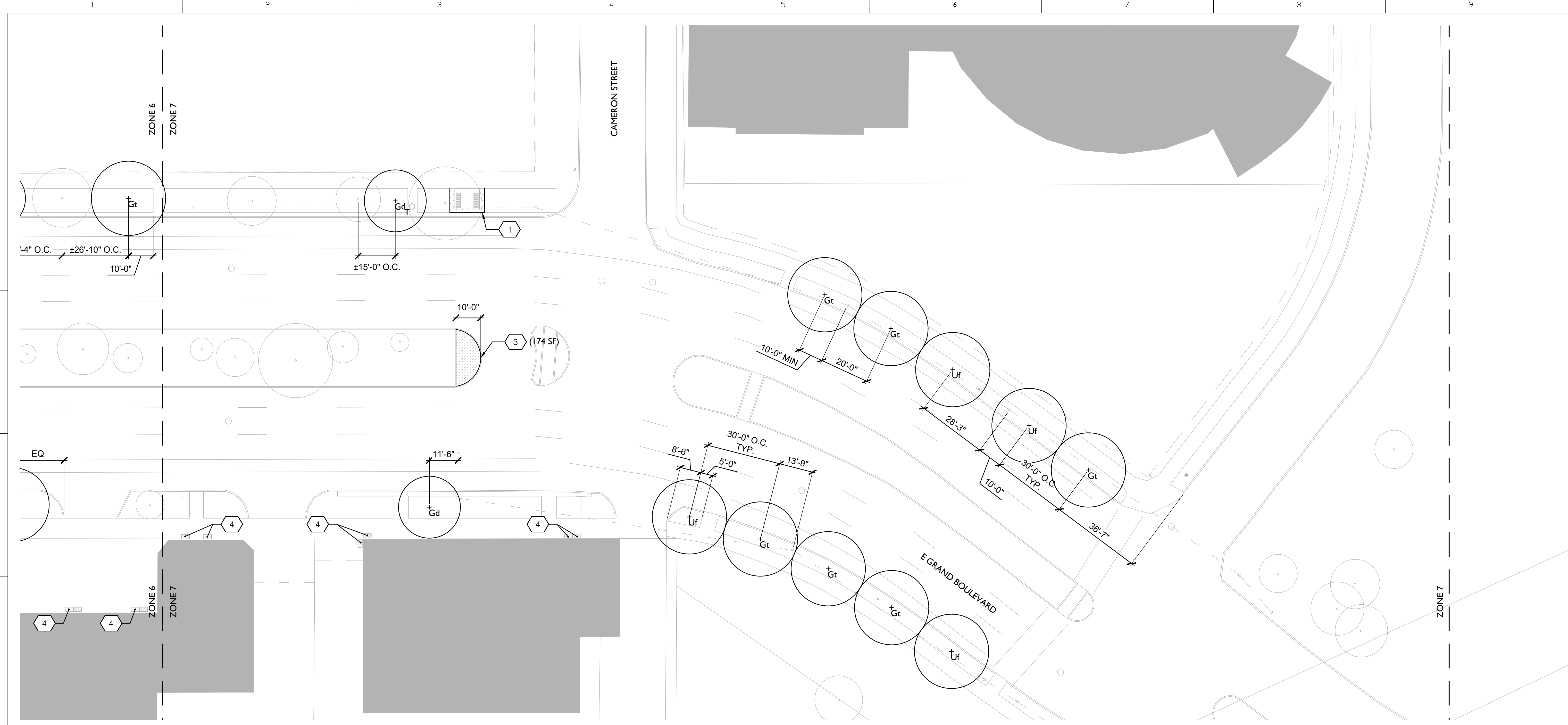

**1 PLANTING PLAN - ZONE 7**  
Scale: 1"=20'-0"

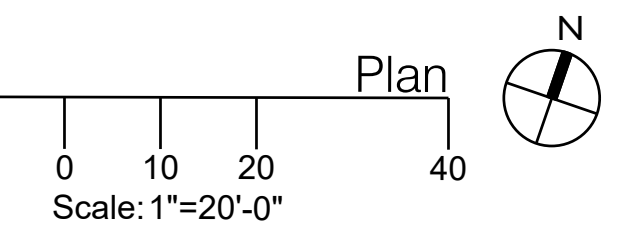

**STATUS:**  
100% CONSTRUCTION DOCUMENTS

**DATE:**  
21 SEPTEMBER 2022

**REVISION**  
NO. DESCRIPTION DATE

NO.	DESCRIPTION	DATE



SMM Project No:  
21014

Sheet No:  
**PLANTING PLAN  
ZONE 7**

Sheet No:  
**L507**

**LEGEND**

	LOW LIMIT OF WORK		REPAIR EXISTING SOD AS NEEDED, SEE 3/L591		PLANTING IN PLANTERS, BY OTHERS
	EXISTING TREES TO REMAIN AND BE PROTECTED		PLANTING BED TYPE 1, SEE 1/L590		
	PROPOSED TREE PLANTING, BY OTHERS		PLANTING BED TYPE 2, SEE L550		

- PLANTING NOTES**
- SEE L550 FOR PLANT SCHEDULE
  - SEE L590-L591 FOR TYPICAL PLANTING DETAILS.
  - CONTRACTOR SHALL RENOVATE EXISTING TURF DAMAGED DURING CONSTRUCTION (32 92 00).
  - LANDSCAPE ARCHITECT TO CONFIRM LOCATION OF ALL PLANT MATERIALS PRIOR TO INSTALLATION.



PLANT SCHEDULE (32 93 00)

TREES

SYMBOL	COMMON NAME	BOTANICAL NAME	QTY	SIZE	SPACING	NOTES
	EASTERN REDBUD	<i>Cercis canadensis</i>	6	3" CAL	REF PLAN	MIN. CROTCH HEIGHT 6'. MUST HAVE STRONG CENTRAL LEADER, SINGLE TRUNK. TREES SHALL BE PROVIDED BY OTHERS. TREES PROVIDED BY OTHERS.
	KENTUCKY COFFEE TREE	<i>Gymnocladus dioica</i>	26	3" CAL	REF PLAN	MIN. CROTCH HEIGHT 6'. MUST HAVE STRONG CENTRAL LEADER, SINGLE TRUNK. TREES SHALL BE PROVIDED BY OTHERS. TREES PROVIDED BY OTHERS.
	HONEY LOCUST	<i>Gleditsia triacanthos</i>	26	3" CAL	REF PLAN	MIN. CROTCH HEIGHT 6'. MUST HAVE STRONG CENTRAL LEADER, SINGLE TRUNK. TREES SHALL BE PROVIDED BY OTHERS. TREES PROVIDED BY OTHERS.
	FRONTIER ELM	<i>Ulmus 'Frontier'</i>	25	3" CAL	REF PLAN	MIN. CROTCH HEIGHT 6'. MUST HAVE STRONG CENTRAL LEADER, SINGLE TRUNK. TREES SHALL BE PROVIDED BY OTHERS. TREES PROVIDED BY OTHERS.

SHRUBS, PERENNIALS, AND/OR GROUNDCOVERS

SYMBOL	COMMON NAME	BOTANICAL NAME	QTY	SIZE	SPACING	NOTES
	CATMINT "WALKER'S LOW"	<i>Nepeta x faassenii</i> "Walker's Low"	90	1 GAL	24" O.C.	
	POWWOW WILD BERRY CONE FLOWER	<i>Echinacea purpurea</i>	50	1 GAL	18" O.C.	
	BLUE STAR JUNIPER	<i>Juniperus squamata</i> 'Blue Star'	145	3 GAL	24" O.C.	
	AUTUMN JOY SEDUM	<i>Sedum 'Autumn Joy'</i>	170	6" POT	12" O.C.	
	SUNSPARKLER SEDUM	<i>Sedum 'SunSparkler'</i>	150	6" POT	12" O.C.	
	DEAD-NETTLES	<i>Lamium spp.</i>	100 SF	1 GAL	12" O.C.	TRIANGULAR SPACING
	SEASONAL ANNUALS		100 SF	4" POTS	8" O.C.	TBD BY LANDSCAPE ARCHITECT
	LAWN- KENTUCKY BLUEGRASS	<i>Poa pratensis</i>	1,390 SF	SOD		REPAIR EXISTING LAWN AS NEEDED
	HARDWOOD MULCH		2,250 SF			3" LAYER AT ALL PLANTING BEDS, PLANTERS, AND 4' RADIUS AROUND ALL TREES

PLANTING BED TYPE 2

	50% YARROW 'SAUCY SEDUCTION'	<i>Achillea millefolium</i> 'Saucy Seduction'	360 SF	1 GAL	12" O.C.	TRIANGULAR SPACING
	30% RUSSIAN SAGE 'LACEY BLUE'	<i>Perovskia atriplicifolia</i> 'Lacey Blue'	220 SF	1 GAL	18" O.C.	TRIANGULAR SPACING
	20% POWWOW WILD BERRY CONE FLOWER	<i>Echinacea purpurea</i>	150 SF	3 GAL	18" O.C.	TRIANGULAR SPACING
	SEASONAL ANNUALS		150 SF	4" POTS	8" O.C.	TBD BY LANDSCAPE ARCHITECT

**spackman  
mossop  
michaels**  
440 Burroughs Street  
Suite 696  
Detroit | MI | 48202  
T: 313.720.1055  
LANDSCAPE ARCHITECTS

**EAST GRAND BOULEVARD  
STREETSCAPE TRANSFORMATION**  
E GRAND BLVD, DETROIT

**STATUS:**  
100% CONSTRUCTION DOCUMENTS

**DATE:**  
21 SEPTEMBER 2022

**REVISION**  
NO. DESCRIPTION DATE



9/21/2022

SMM Project No:  
21014

Sheet No:

**PLANT  
SCHEDULE**

Sheet No:

**L550**

- NOTES:**
1. SEE L591 FOR PLANTING DETAILS.
  2. SEE PLANT SCHEDULE L550.
  3. LANDSCAPE ARCHITECT TO CONFIRM LOCATION OF ALL PLANT MATERIALS PRIOR TO INSTALLATION.

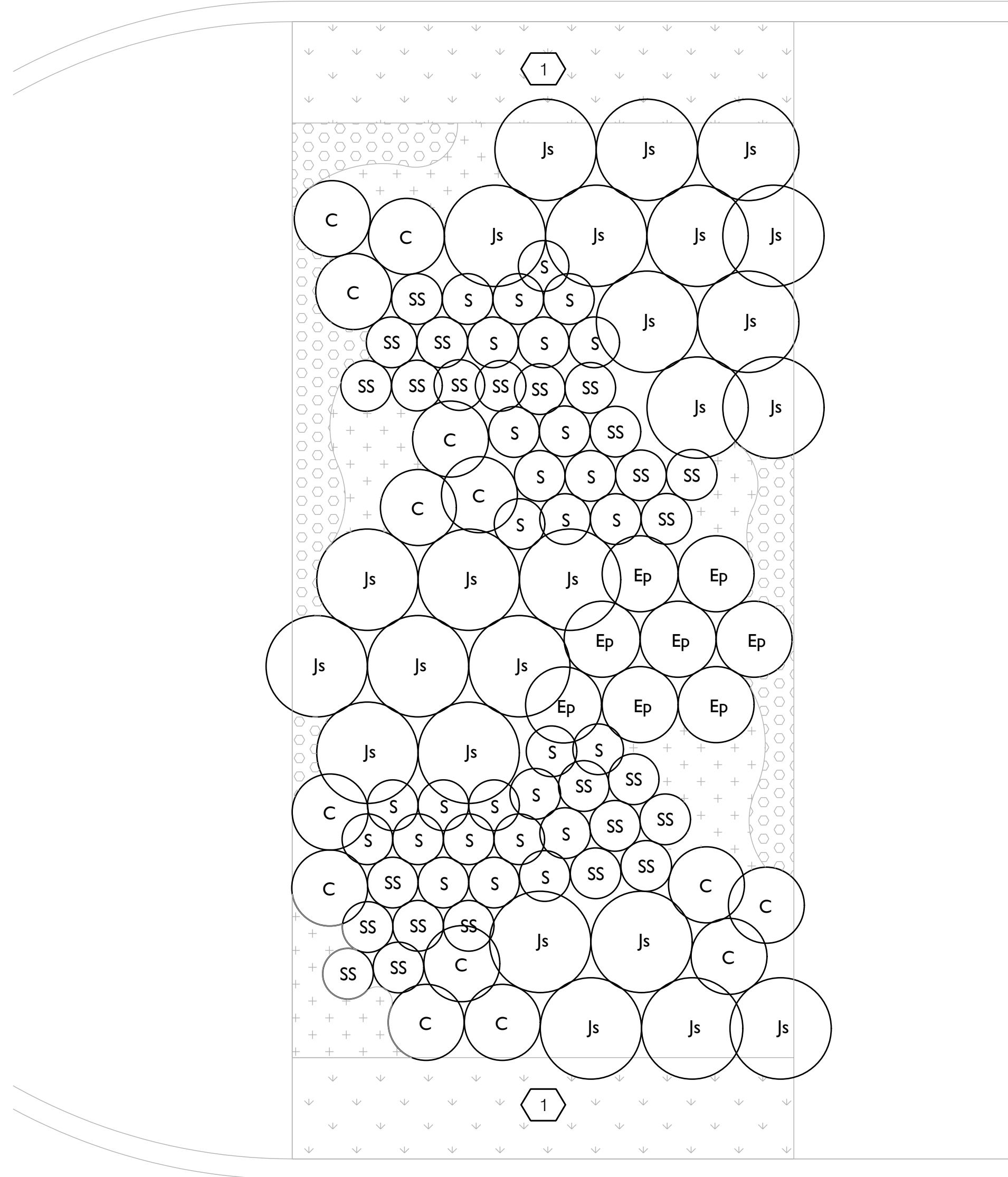

**1** PLANTING BED TYPE 1  
1/2"=1'-0"

PLANTING PLAN  
0 1 2 4  
Scale: 1/2"=1'-0"

**spackman  
mossop  
michaels**  
440 Burroughs Street  
Suite 696  
Detroit | MI | 48202  
T: 313.720.1055  
LANDSCAPE ARCHITECTS

**EAST GRAND BOULEVARD  
STREETSCAPE TRANSFORMATION**  
E GRAND BLVD, DETROIT

**STATUS:**  
100% CONSTRUCTION DOCUMENTS

**DATE:**  
21 SEPTEMBER 2022

**REVISION**

NO.	DESCRIPTION	DATE

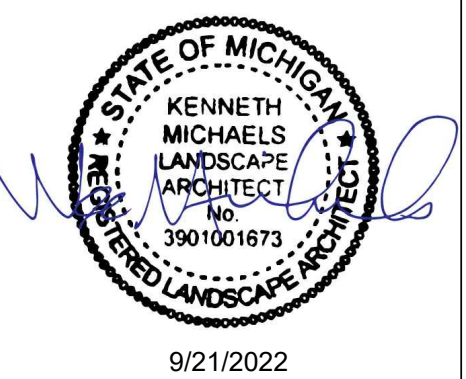

SMM Project No:  
21014

Sheet No:  
**PLANTING  
DETAILS**

Sheet No:  
**L590**



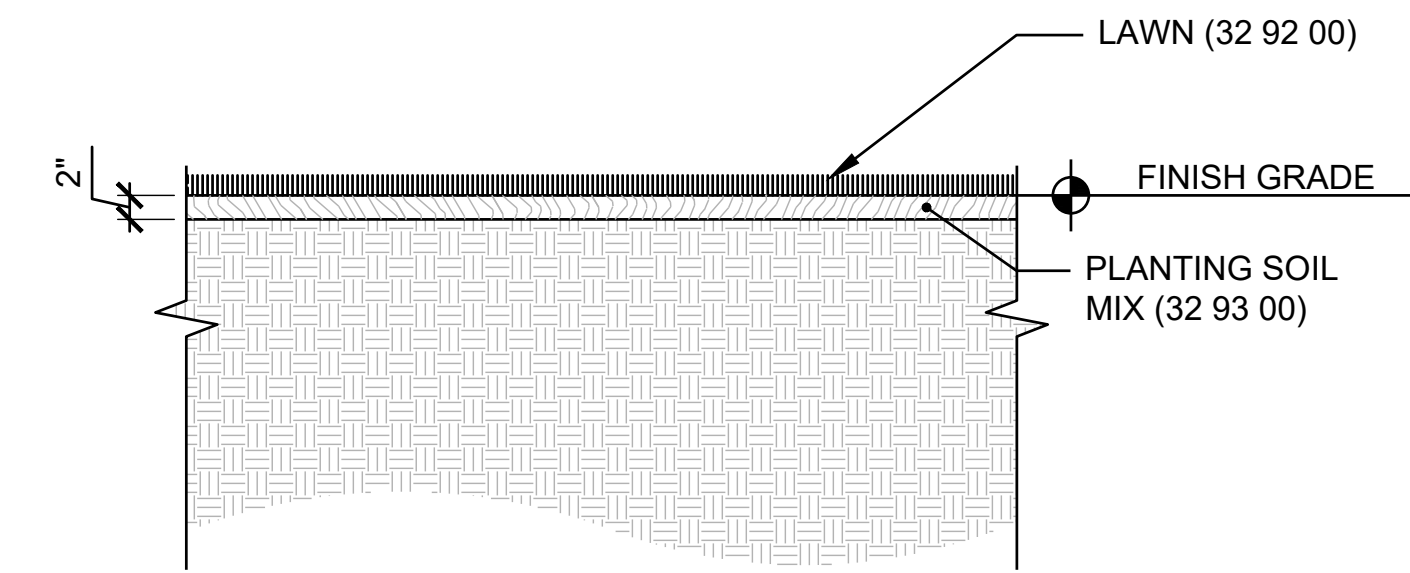
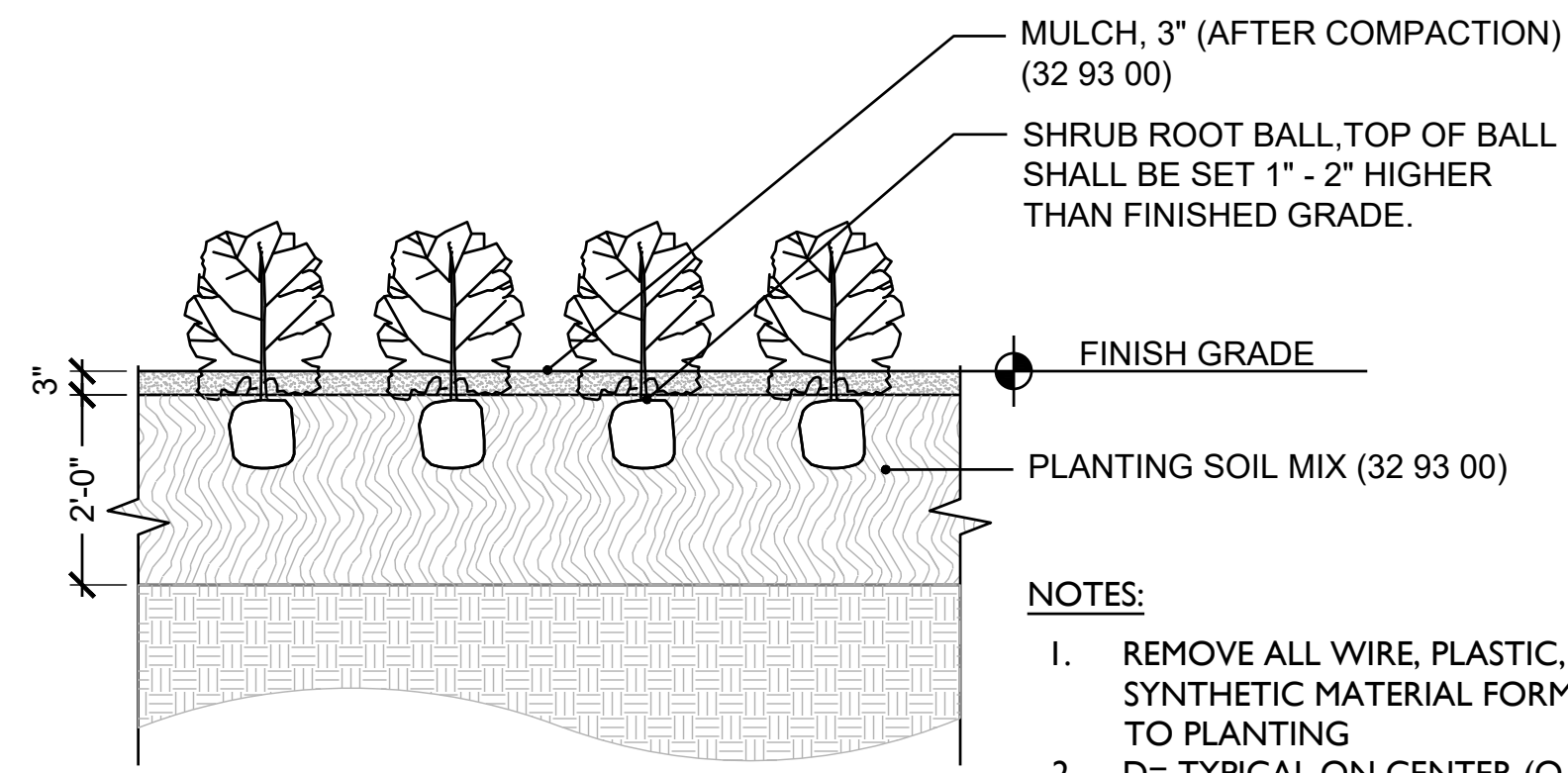
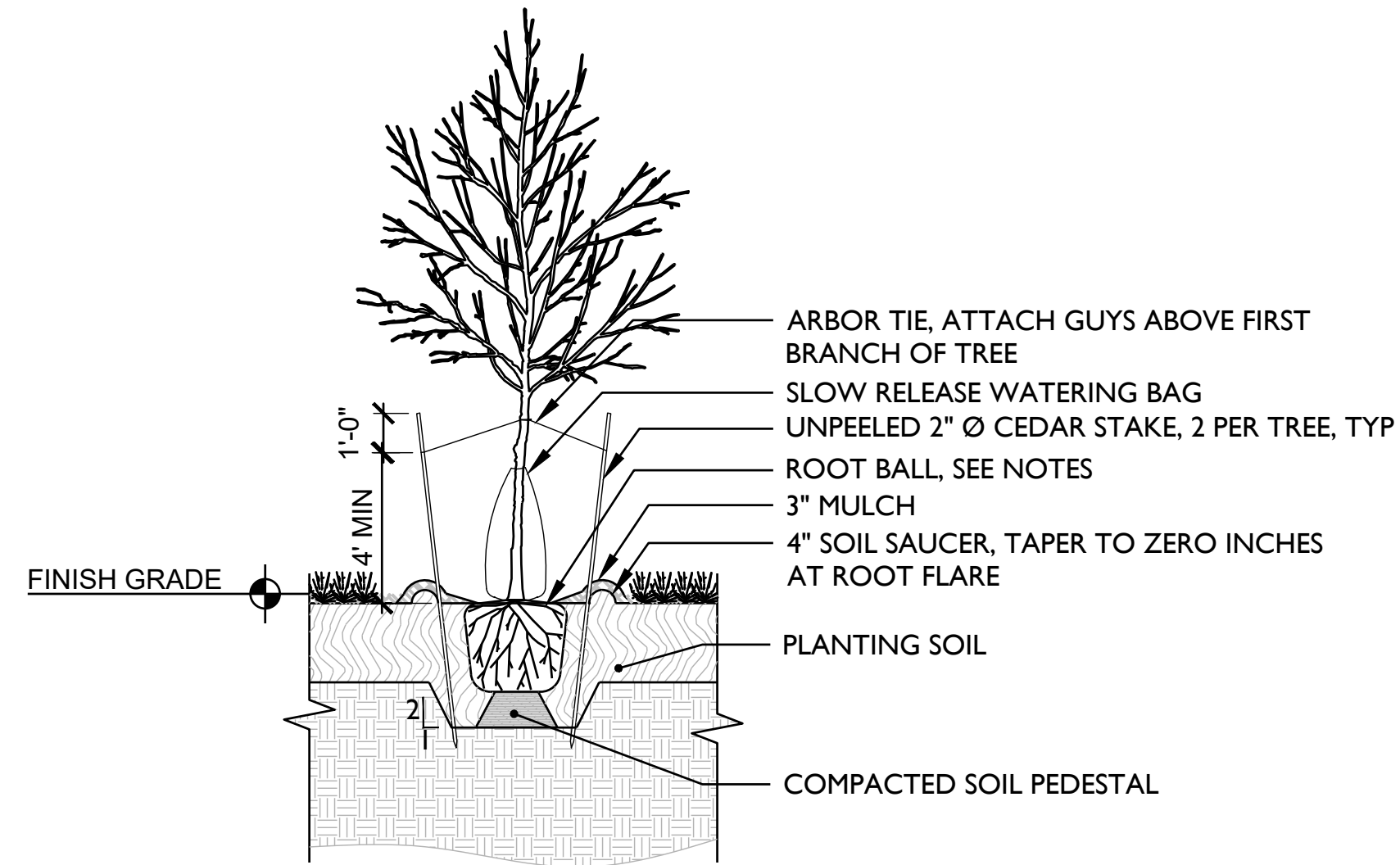
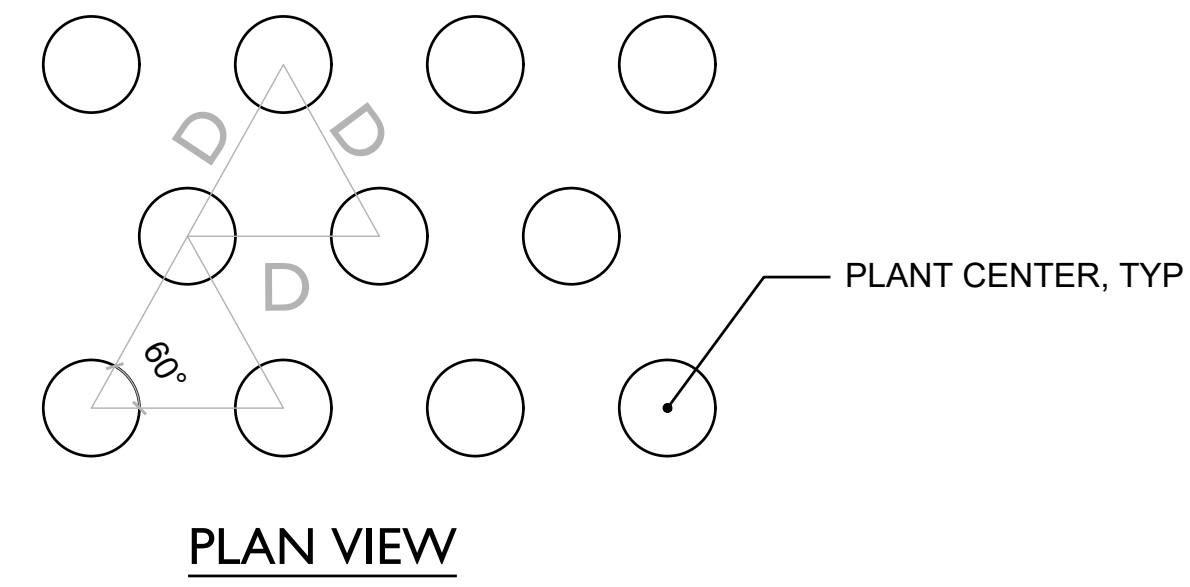
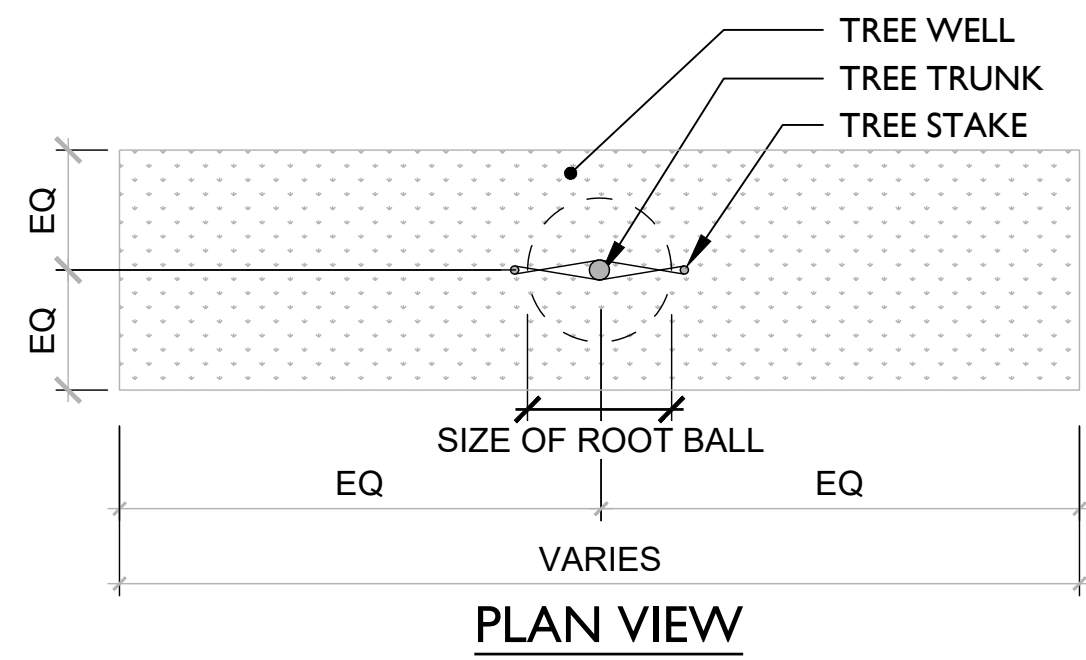

1 TREE PLANTING AND ANCHORING, TYP  
1/4"=1'-0" DETAIL

2 SHRUB & GROUNDCOVER PLANTING LAYOUT PLAN, TYP  
1/2"=1'-0" DETAIL

3 LAWN, TYP  
1"=1'-0" DETAIL

EAST GRAND BOULEVARD  
STREETSCAPE TRANSFORMATION  
E GRAND BLVD, DETROIT

STATUS:  
100% CONSTRUCTION DOCUMENTS

DATE:  
21 SEPTEMBER 2022

REVISION  
NO. DESCRIPTION DATE



SMM Project No:  
21014

Sheet No:  
PLANTING  
DETAILS

Sheet No:  
L591

**EAST GRAND BOULEVARD  
STREETSCAPE TRANSFORMATION**  
E GRAND BLVD, DETROIT

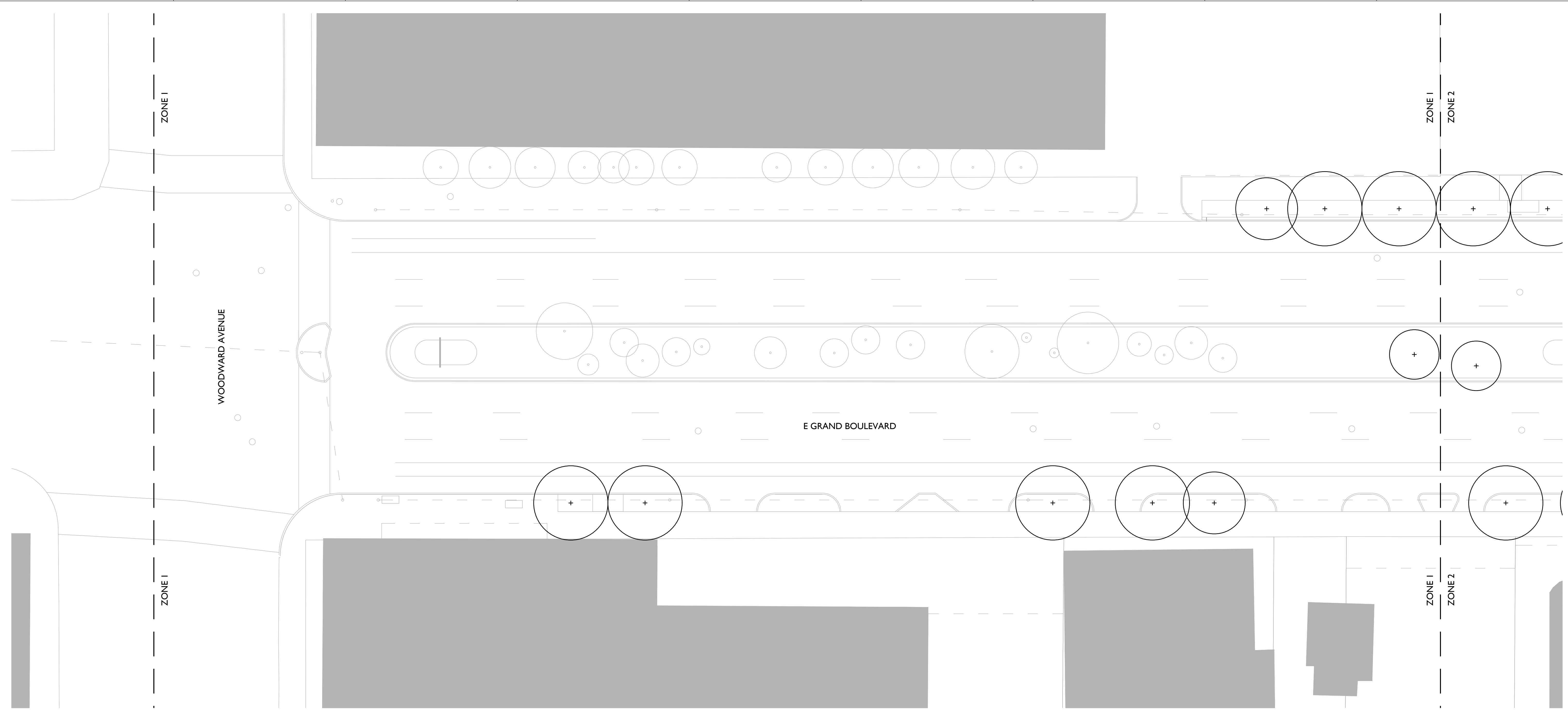

**1** IRRIGATION PLAN - ZONE 1  
Scale: 1"=20'-0"

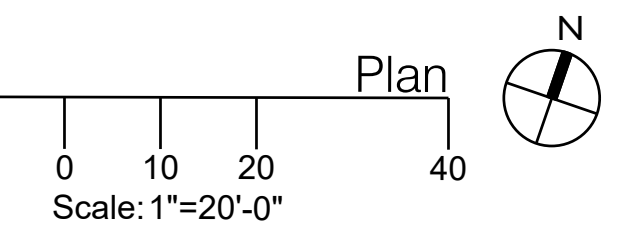

**STATUS:**  
100% CONSTRUCTION DOCUMENTS

**DATE:**  
21 SEPTEMBER 2022

REVISION NO.	DESCRIPTION	DATE

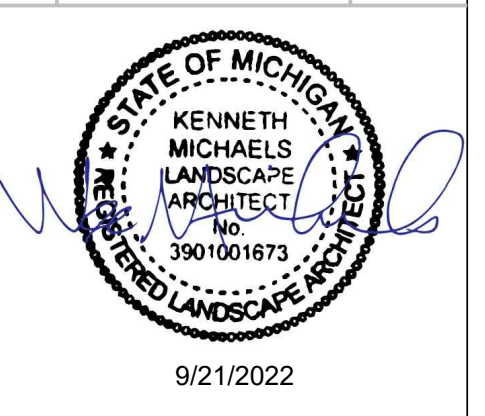

SMM Project No:  
21014

Sheet No:  
**IRRIGATION PLAN  
ZONE I**

Sheet No:  
**L601**

**LEGEND**

	LOW LIMIT OF WORK		AREAS TO BE IRRIGATED (APPROX. 1,975 SF)
	EXISTING TREES TO REMAIN AND BE PROTECTED		
	PROPOSED TREE TO BE IRRIGATED BY OTHERS		

- IRRIGATION NOTES**
- CONTRACTOR TO TIE IN TO EXISTING IRRIGATION SYSTEM.
  - ANY PLANT MATERIAL NOT SHOWN AS IRRIGATED SHALL BE HAND WATERED DURING TIME OF ESTABLISHMENT.



**EAST GRAND BOULEVARD  
STREETSCAPE TRANSFORMATION**  
E GRAND BLVD, DETROIT

**STATUS:**  
100% CONSTRUCTION DOCUMENTS

**DATE:**  
21 SEPTEMBER 2022

REVISION NO.	DESCRIPTION	DATE



SMM Project No:  
21014

Sheet No:  
**IRRIGATION PLAN  
ZONE 2**

Sheet No:  
**L602**

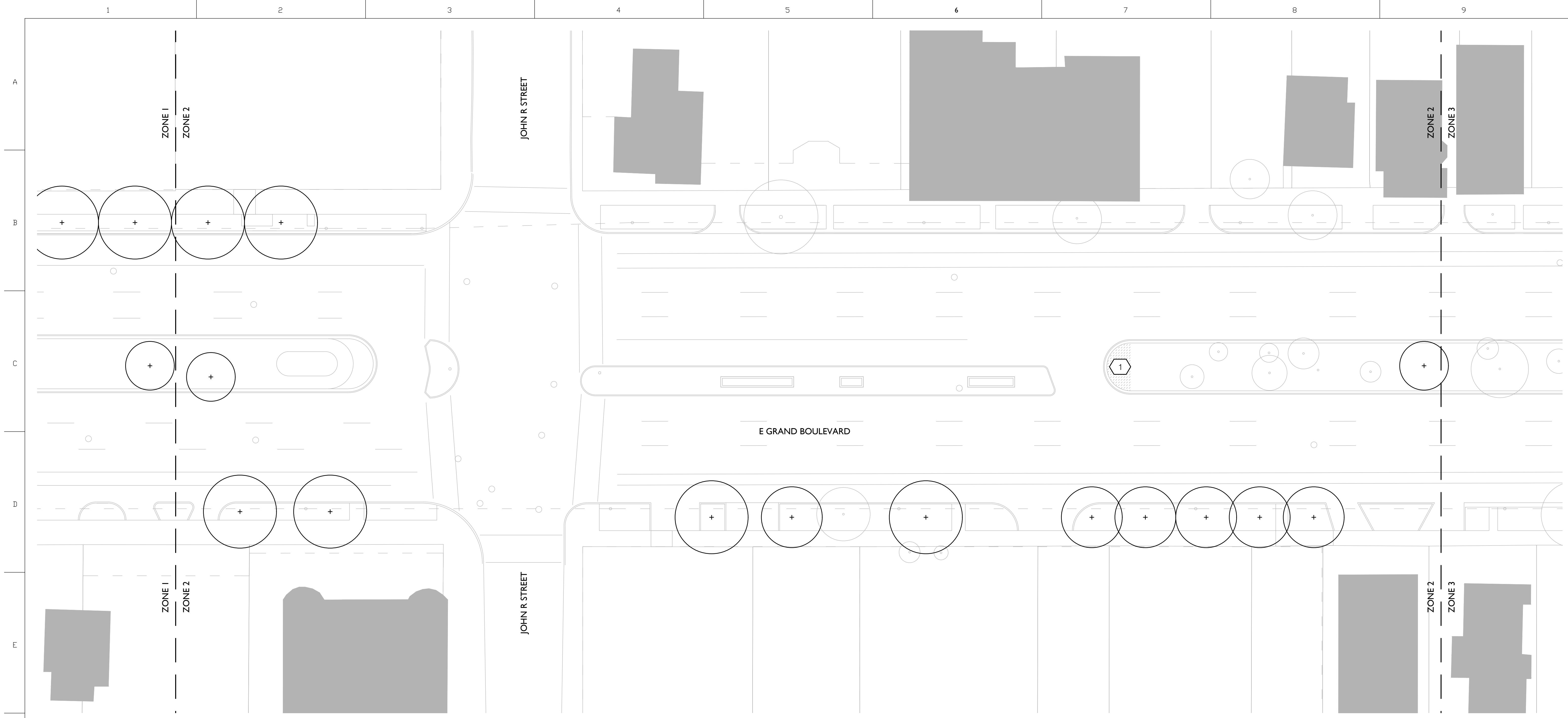

**1** IRRIGATION PLAN - ZONE 2  
Scale: 1"=20'-0"

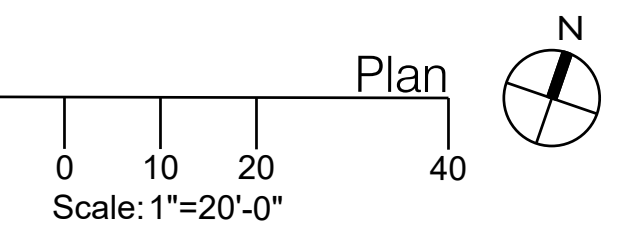

**LEGEND**

	LOW LIMIT OF WORK		AREAS TO BE IRRIGATED (APPROX. 1,975 SF)
	EXISTING TREES TO REMAIN AND BE PROTECTED		
	PROPOSED TREE TO BE IRRIGATED BY OTHERS		

- IRRIGATION NOTES**
- CONTRACTOR TO TIE IN TO EXISTING IRRIGATION SYSTEM.
  - ANY PLANT MATERIAL NOT SHOWN AS IRRIGATED SHALL BE HAND WATERED DURING TIME OF ESTABLISHMENT.

**EAST GRAND BOULEVARD  
STREETSCAPE TRANSFORMATION**  
E GRAND BLVD, DETROIT

**STATUS:**  
100% CONSTRUCTION DOCUMENTS

**DATE:**  
21 SEPTEMBER 2022

**REVISION**  
NO. DESCRIPTION DATE

NO.	DESCRIPTION	DATE



SMM Project No:  
21014

Sheet No:  
**IRRIGATION PLAN  
ZONE 3**

Sheet No:  
**L603**

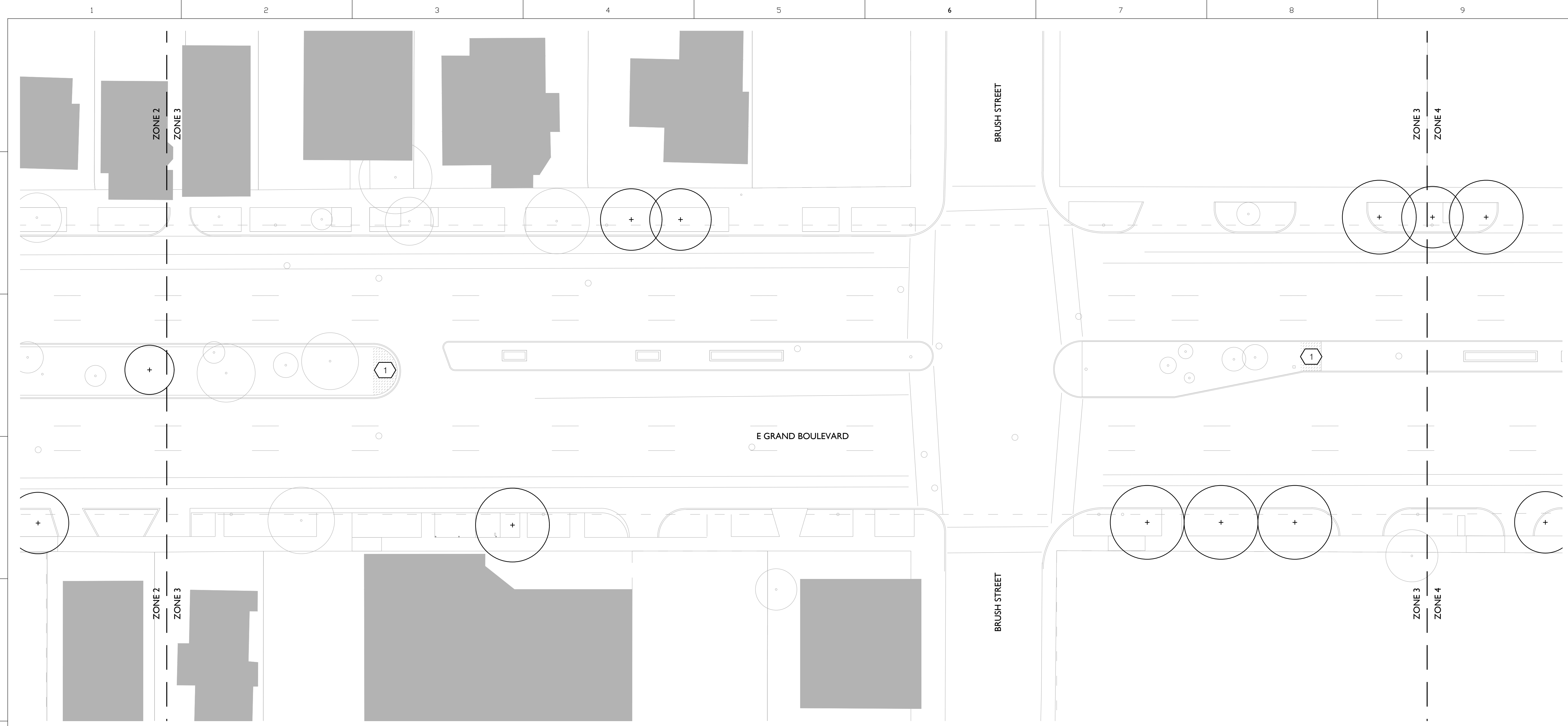

**1** IRRIGATION PLAN - ZONE 3  
Scale: 1"=20'-0"

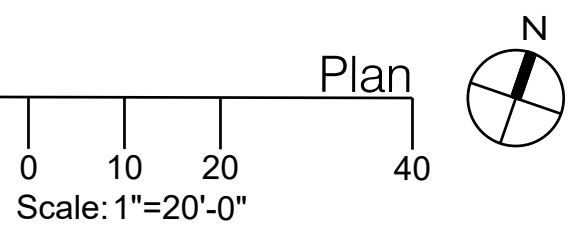

**LEGEND**

	LOW LIMIT OF WORK		AREAS TO BE IRRIGATED (APPROX. 1,975 SF)
	EXISTING TREES TO REMAIN AND BE PROTECTED		
	PROPOSED TREE TO BE IRRIGATED BY OTHERS		

- IRRIGATION NOTES**
- CONTRACTOR TO TIE IN TO EXISTING IRRIGATION SYSTEM.
  - ANY PLANT MATERIAL NOT SHOWN AS IRRIGATED SHALL BE HAND WATERED DURING TIME OF ESTABLISHMENT.



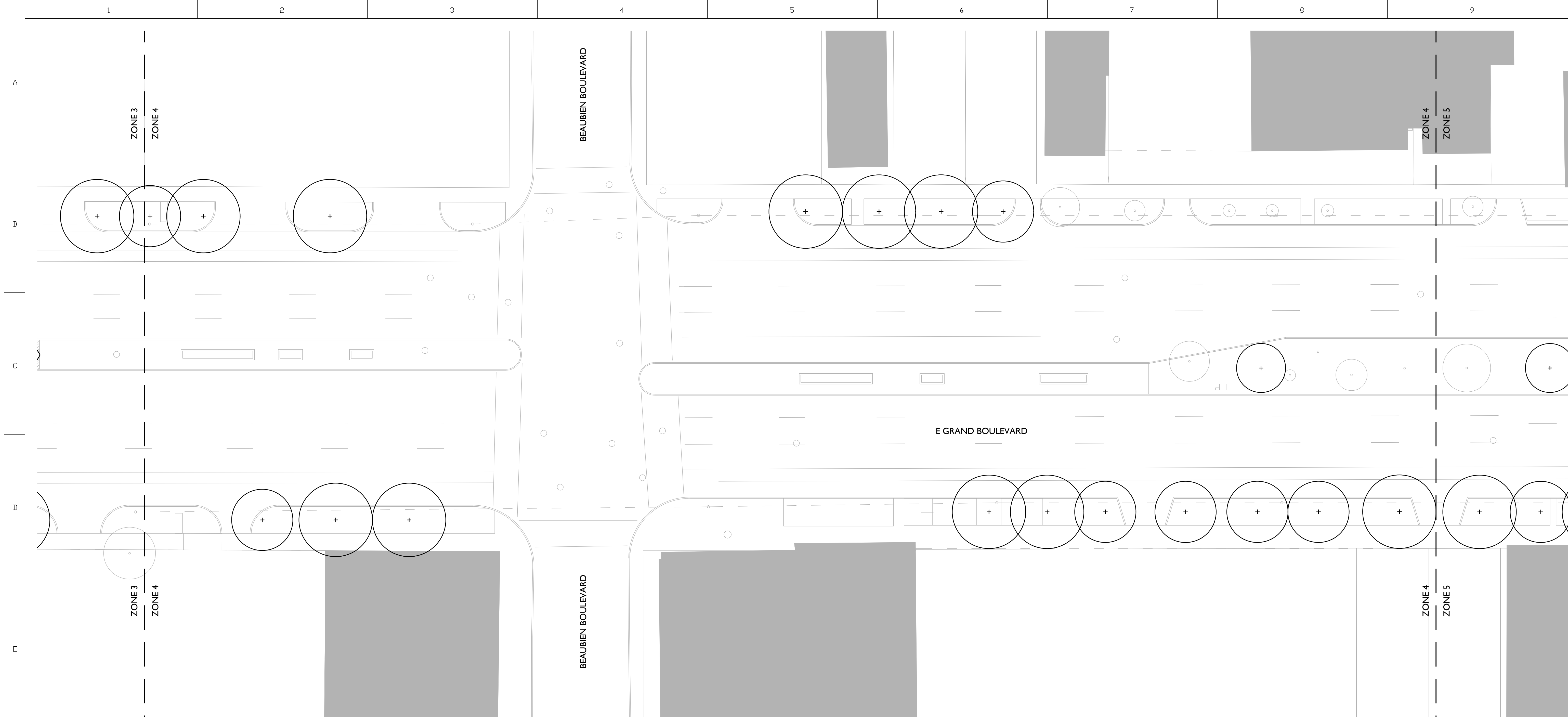

**spackman  
mossop  
michaels**  
440 Burroughs Street  
Suite 696  
Detroit | MI | 48202  
T: 313.720.1055  
LANDSCAPE ARCHITECTS

**EAST GRAND BOULEVARD  
STREETSCAPE TRANSFORMATION**  
E GRAND BLVD, DETROIT

**1** IRRIGATION PLAN - ZONE 4  
Scale: 1"=20'-0"

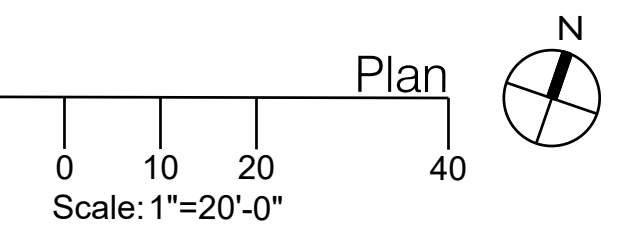



**STATUS:**  
100% CONSTRUCTION DOCUMENTS

**DATE:**  
21 SEPTEMBER 2022

REVISION		
NO.	DESCRIPTION	DATE

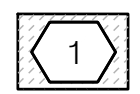
**LEGEND**

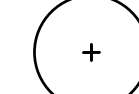
	<b>LOW</b>	LIMIT OF WORK		AREAS TO BE IRRIGATED (APPROX. 1,975 SF)
		EXISTING TREES TO REMAIN AND BE PROTECTED		
		PROPOSED TREE TO BE IRRIGATED BY OTHERS		

- IRRIGATION NOTES**
1. CONTRACTOR TO TIE IN TO EXISTING IRRIGATION SYSTEM.
  2. ANY PLANT MATERIAL NOT SHOWN AS IRRIGATED SHALL BE HAND WATERED DURING TIME OF ESTABLISHMENT.



SMM Project No:  
21014

Sheet No:  
**IRRIGATION PLAN  
ZONE 4**

Sheet No:  
**L604**

EAST GRAND BOULEVARD  
STREETSCAPE TRANSFORMATION  
E GRAND BLVD, DETROIT

STATUS:  
100% CONSTRUCTION DOCUMENTS

DATE:  
21 SEPTEMBER 2022

REVISION  
NO. DESCRIPTION DATE

NO.	DESCRIPTION	DATE



SMM Project No:  
21014

Sheet No:  
IRRIGATION PLAN  
ZONE 5

Sheet No:  
L605

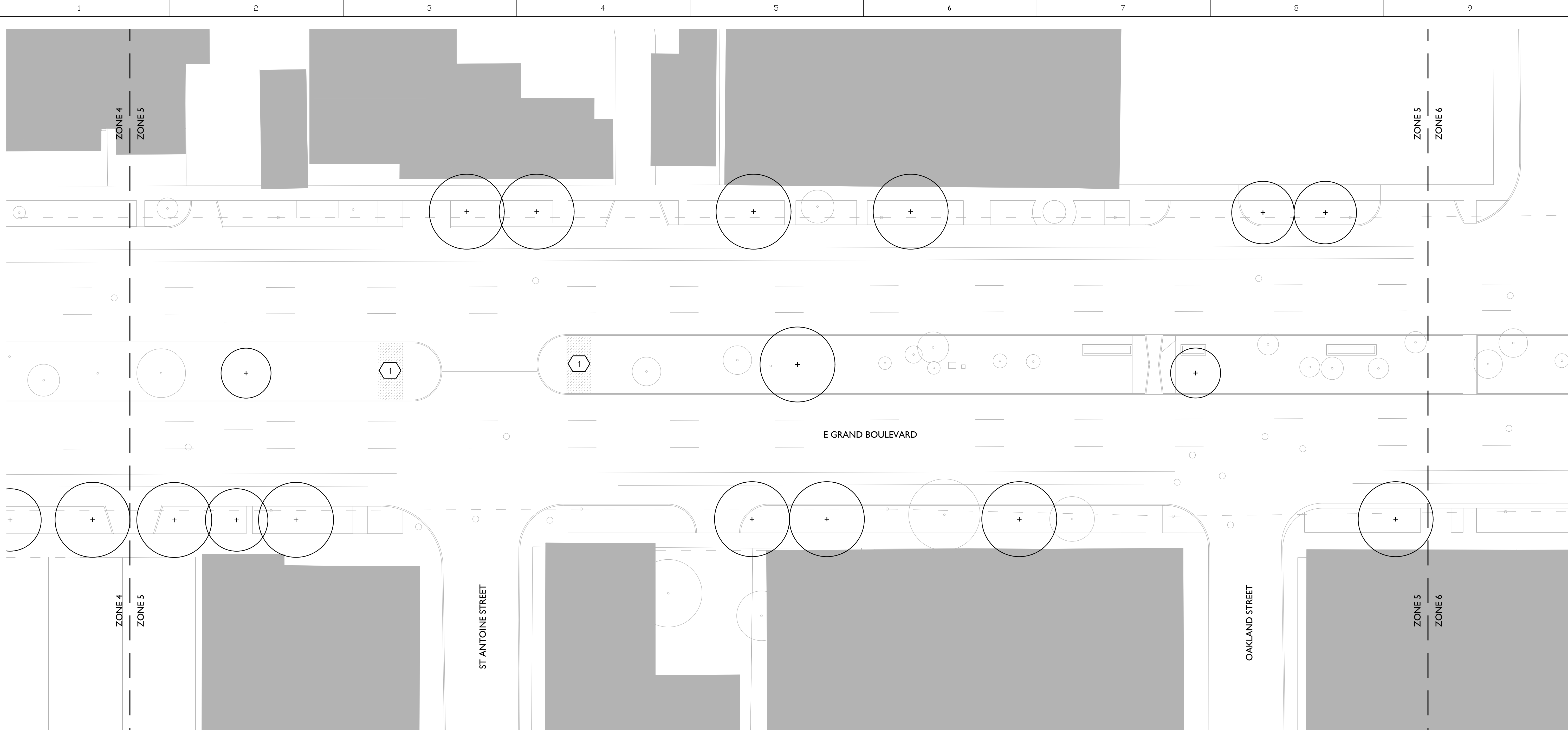

1 IRRIGATION PLAN - ZONE 5  
Scale: 1"=20'-0"

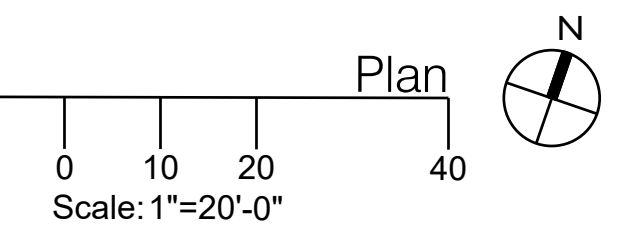

LEGEND

	LOW LIMIT OF WORK		AREAS TO BE IRRIGATED (APPROX. 1,975 SF)
	EXISTING TREES TO REMAIN AND BE PROTECTED		
	PROPOSED TREE TO BE IRRIGATED BY OTHERS		

- IRRIGATION NOTES
- CONTRACTOR TO TIE IN TO EXISTING IRRIGATION SYSTEM.
  - ANY PLANT MATERIAL NOT SHOWN AS IRRIGATED SHALL BE HAND WATERED DURING TIME OF ESTABLISHMENT.





**EAST GRAND BOULEVARD  
STREETSCAPE TRANSFORMATION**  
E GRAND BLVD, DETROIT

**STATUS:**  
100% CONSTRUCTION DOCUMENTS

**DATE:**  
21 SEPTEMBER 2022

REVISION NO.	DESCRIPTION	DATE

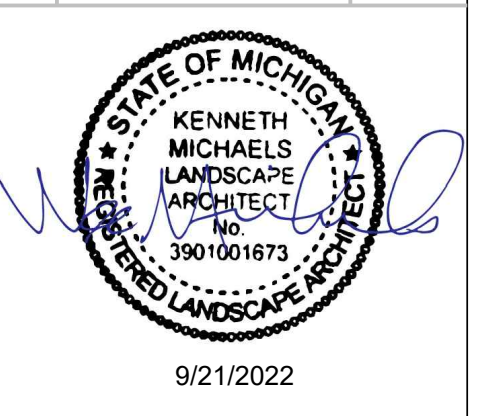

SMM Project No:  
21014

Sheet No:  
**IRRIGATION PLAN  
ZONE 7**

Sheet No:  
**L607**

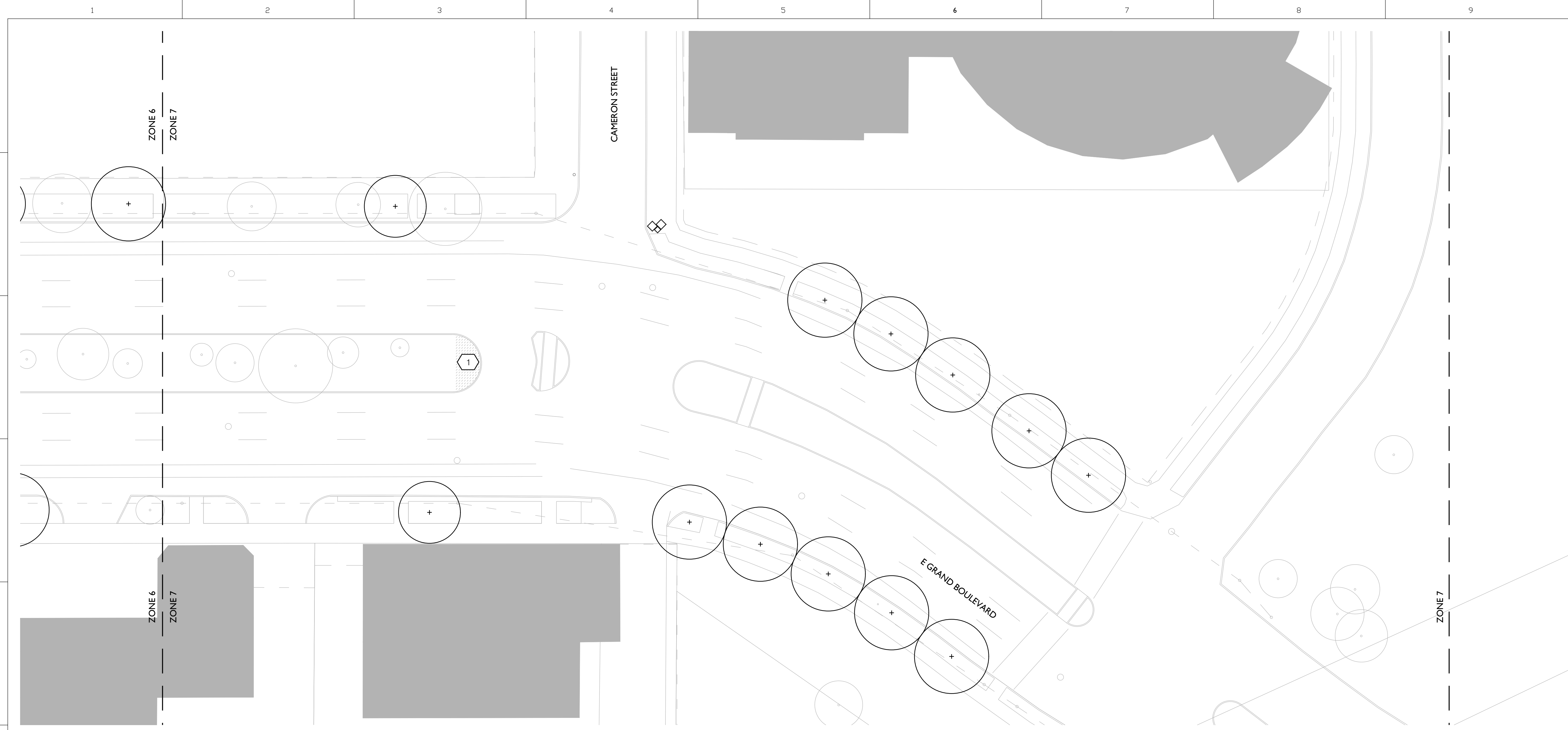

**1** IRRIGATION PLAN - ZONE 7  
Scale: 1"=20'-0"

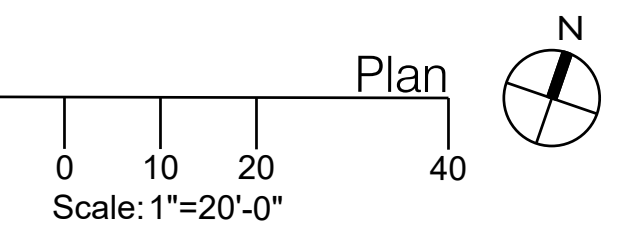

**LEGEND**

	LOW LIMIT OF WORK		AREAS TO BE IRRIGATED (APPROX. 1,975 SF)
	EXISTING TREES TO REMAIN AND BE PROTECTED		
	PROPOSED TREE TO BE IRRIGATED BY OTHERS		

- IRRIGATION NOTES**
- CONTRACTOR TO TIE IN TO EXISTING IRRIGATION SYSTEM.
  - ANY PLANT MATERIAL NOT SHOWN AS IRRIGATED SHALL BE HAND WATERED DURING TIME OF ESTABLISHMENT.



EAST GRAND BOULEVARD  
STREETSCAPE TRANSFORMATION  
E GRAND BLVD, DETROIT

STATUS:  
100% CONSTRUCTION DOCUMENTS

DATE:  
21 SEPTEMBER 2022

REVISION  
NO. DESCRIPTION DATE

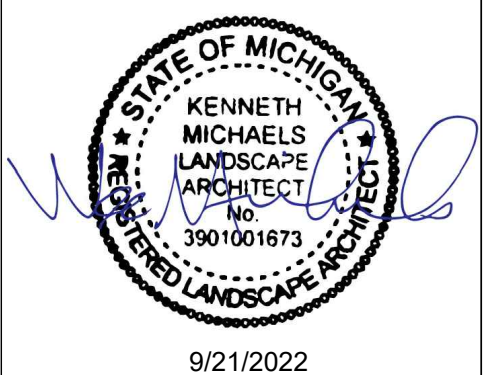

SMM Project No:  
21014

Sheet No:  
**MATERIALS  
ENLARGEMENT  
PLAN**

Sheet No:  
**L801**

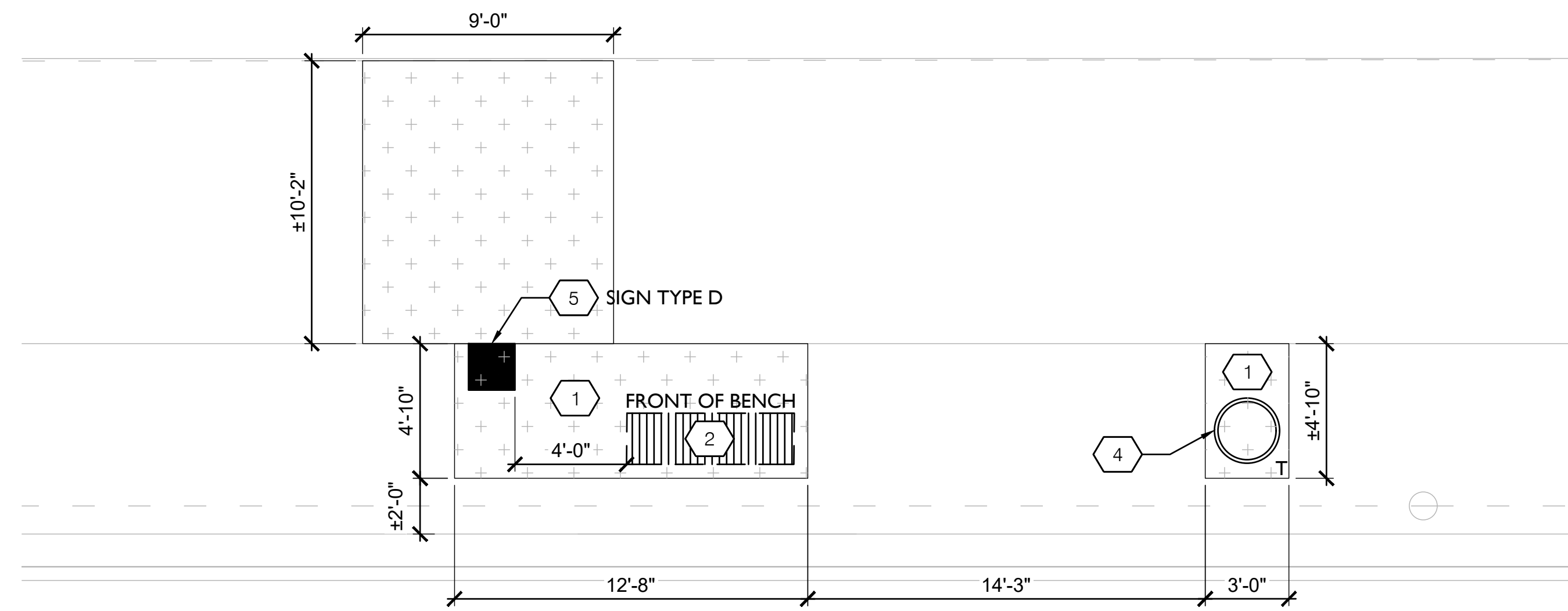

2 MATERIALS ENLARGEMENT PLAN - ZONE 2  
Scale: 1/4"=1'-0"

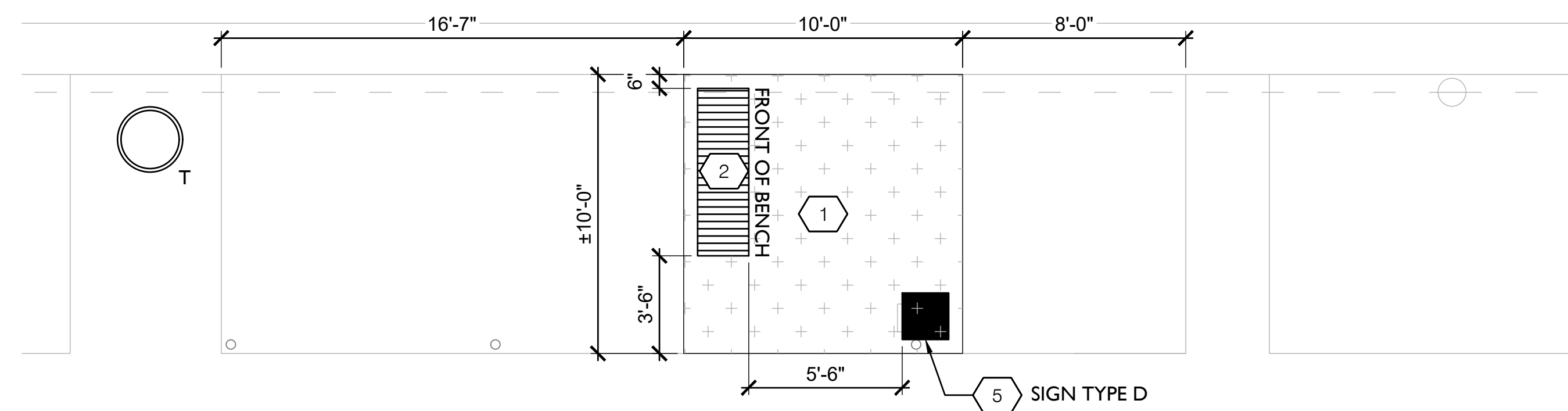
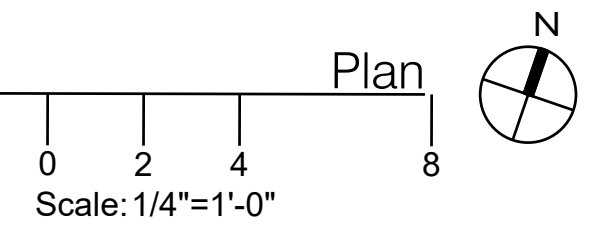

4 MATERIALS ENLARGEMENT PLAN - ZONE 3B  
Scale: 1/4"=1'-0"

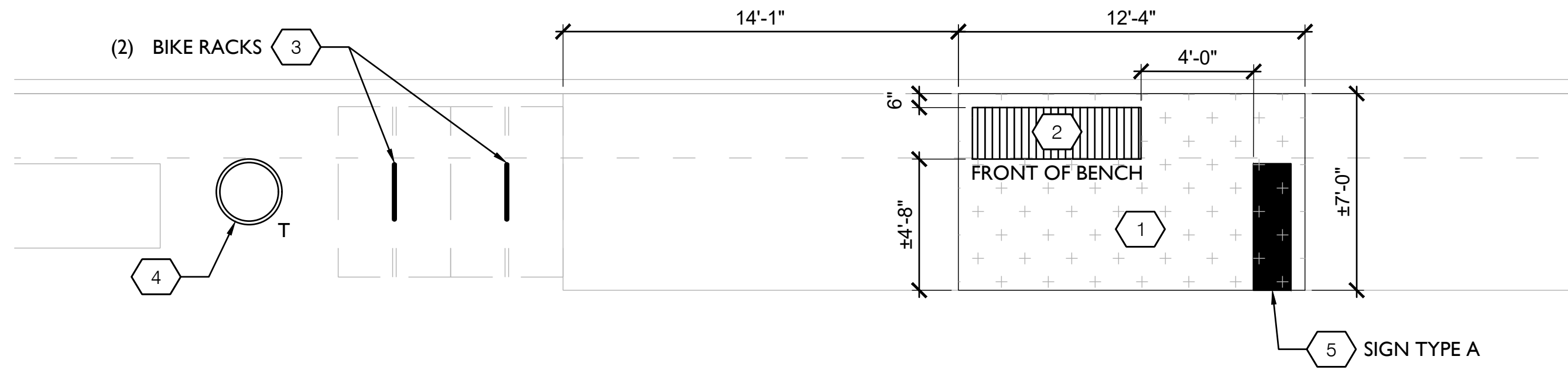
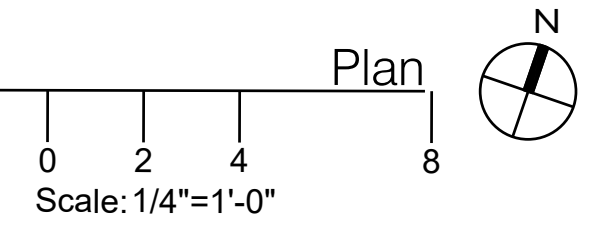

1 MATERIALS ENLARGEMENT PLAN - ZONE 1  
Scale: 1/4"=1'-0"

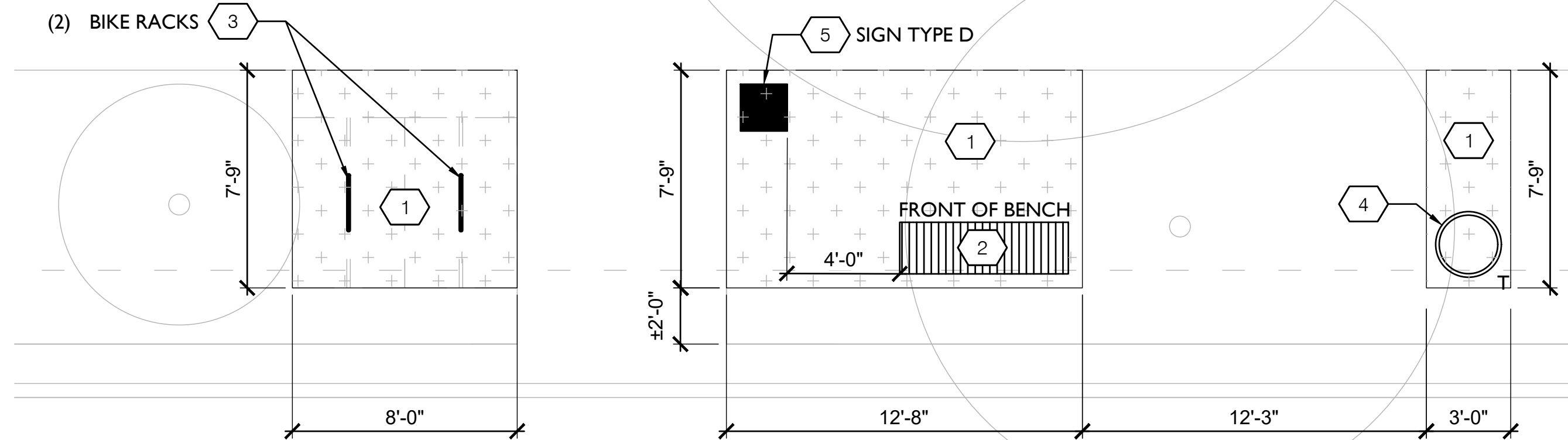
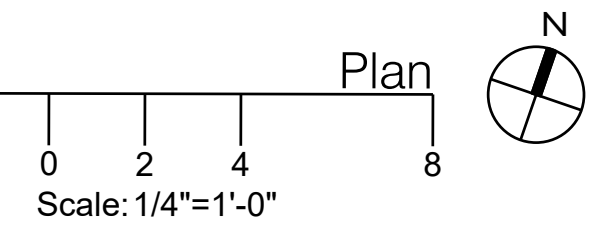

3 MATERIALS ENLARGEMENT PLAN - ZONE 3A  
Scale: 1/4"=1'-0"

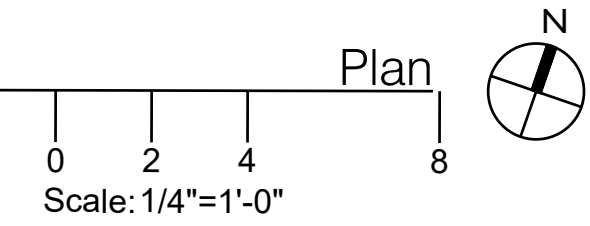

LEGEND

LOW	LIMIT OF WORK	1 NEW CONCRETE SIDEWALK, SEE 1/L910	4 TRASH CANS, SEE 3/L910	7 BENCH SWING, SEE 1/L911	10 TOUCH UP EXISTING CROSSWALKS, BY CITY
	EXISTING TREES TO REMAIN AND BE PROTECTED	2 BENCHES, SEE 2/L910	5 VERTICAL STORYTELLING, SEE 1/L912	8 SOLAR-POWERED CHARGING STATION, SEE 2/L911	11 ARTISTIC CROSSWALKS, SEE 2/L900
		3 BIKE RACKS, SEE 1/L910	6 PLANTERS, SEE L250	9 ART MURAL AT MEDIAN, SEE 3/L900	

NOTES

1. MAINTAIN MAX 4.5% SLOPE AND 2% CROSS SLOPE ACROSS ALL SIDEWALKS.
2. CONTRACTOR TO VERIFY ALL DIMENSIONS IN FIELD.
3. SEE L250 FOR SITE FURNISHINGS SCHEDULE.
4. SEE L900 SERIES FOR DETAILS.

**EAST GRAND BOULEVARD  
STREETSCAPE TRANSFORMATION**  
E GRAND BLVD, DETROIT

**STATUS:**  
100% CONSTRUCTION DOCUMENTS

**DATE:**  
21 SEPTEMBER 2022

**REVISION**

NO.	DESCRIPTION	DATE



SMM Project No:  
21014

Sheet No:  
**MATERIALS  
ENLARGEMENT  
PLAN**

Sheet No:  
**L802**

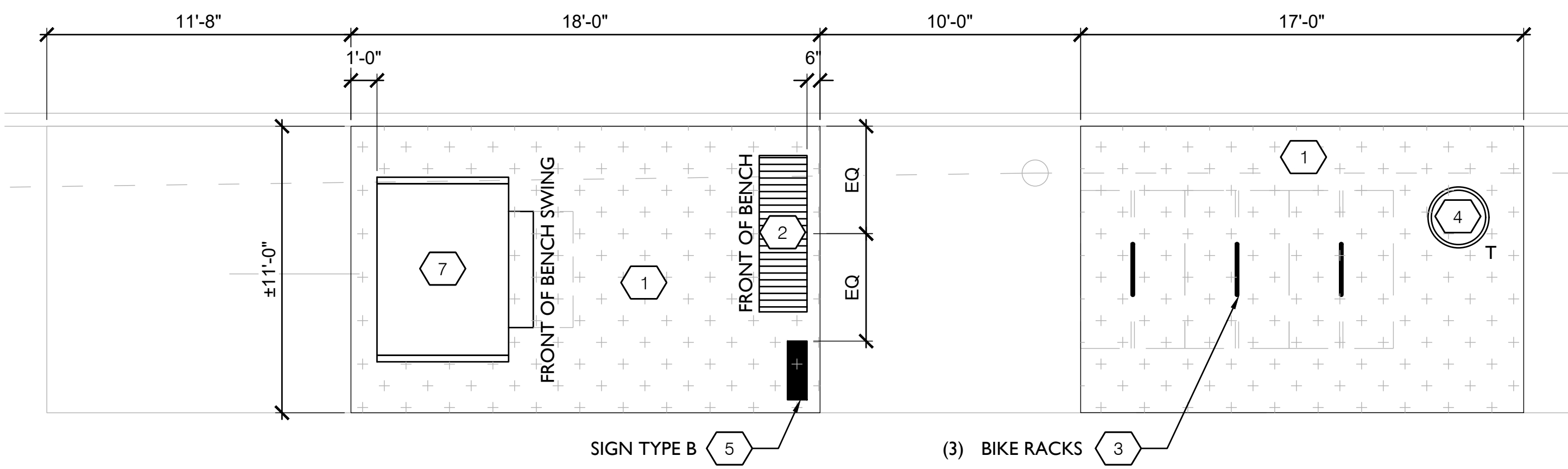

**1** MATERIALS ENLARGEMENT PLAN - ZONE 4  
Scale: 1/4"=1'-0"

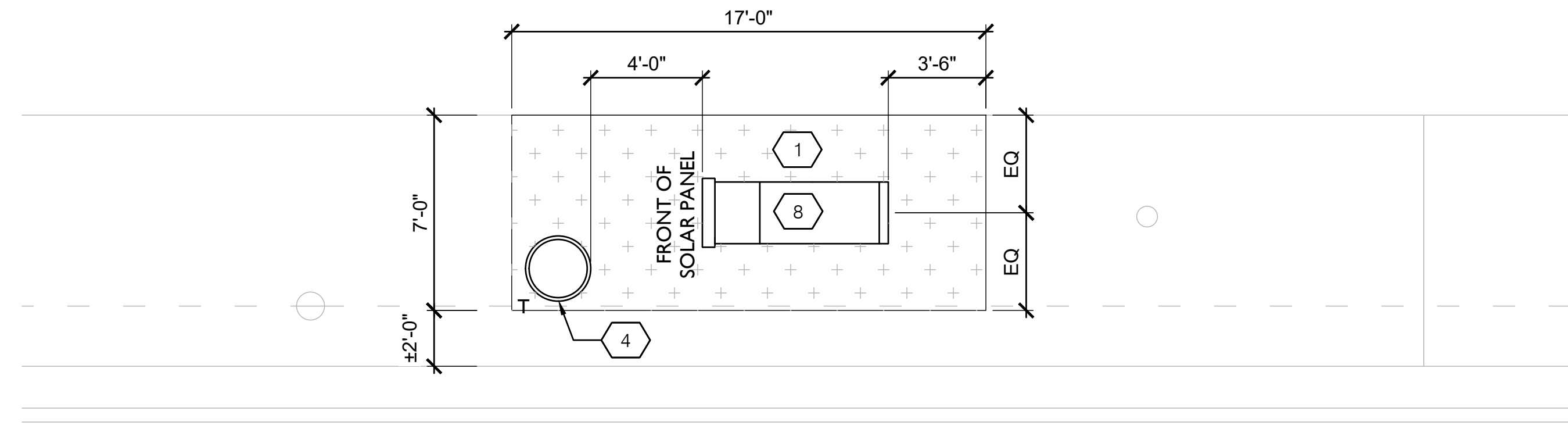
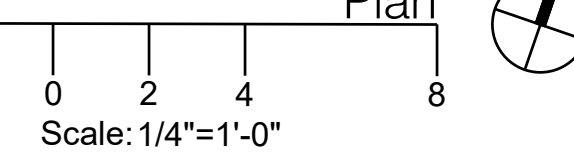

**2** MATERIALS ENLARGEMENT PLAN - ZONE 5  
Scale: 1/4"=1'-0"

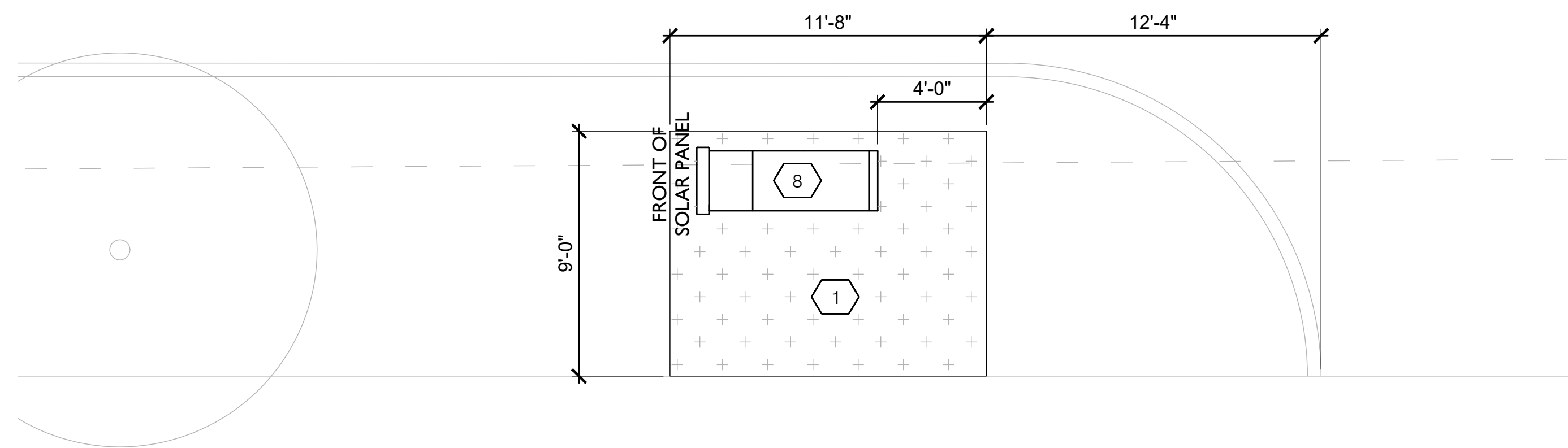
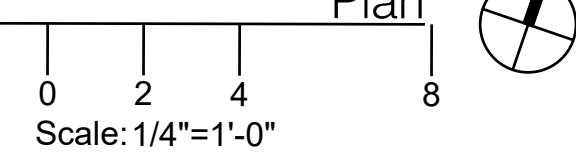

**3** MATERIALS ENLARGEMENT PLAN - ZONE 6A  
Scale: 1/4"=1'-0"

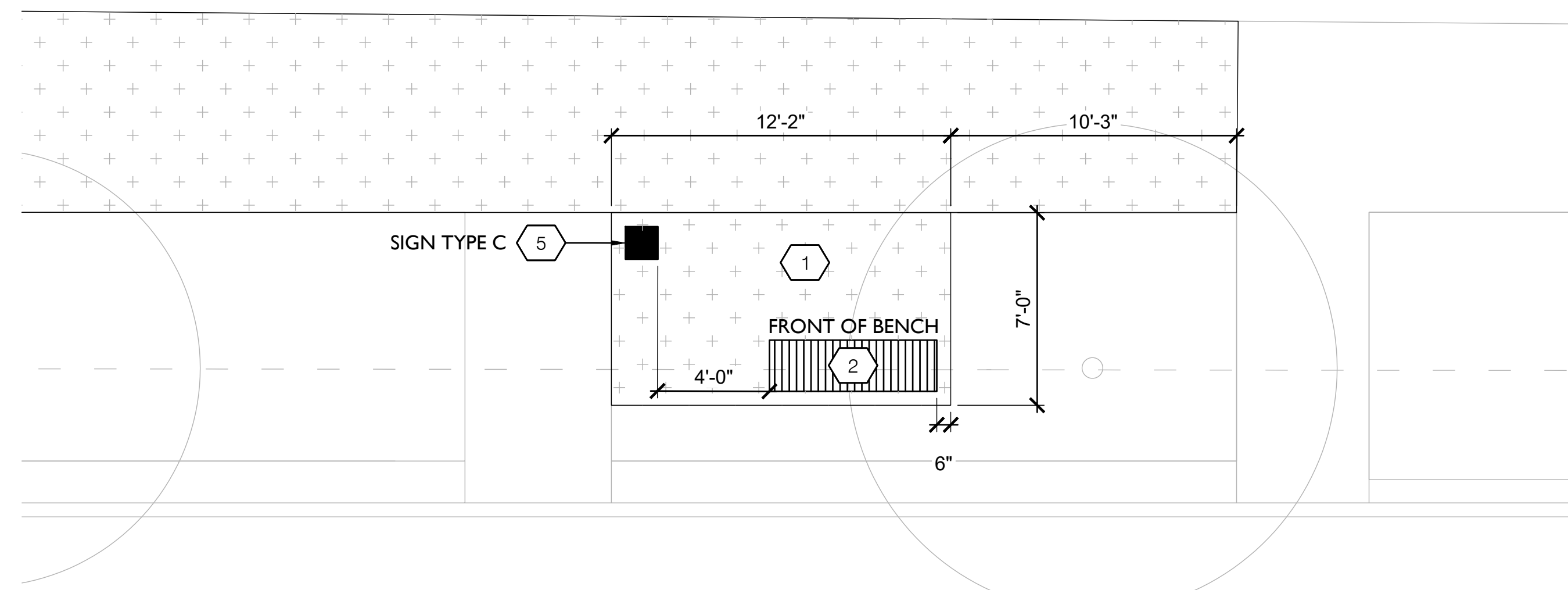
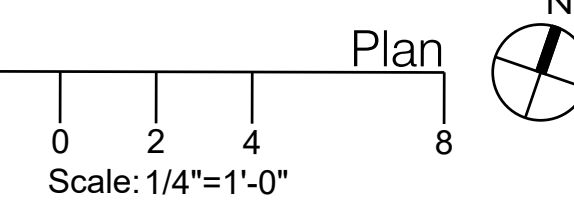

**4** MATERIALS ENLARGEMENT PLAN - ZONE 6B  
Scale: 1/4"=1'-0"

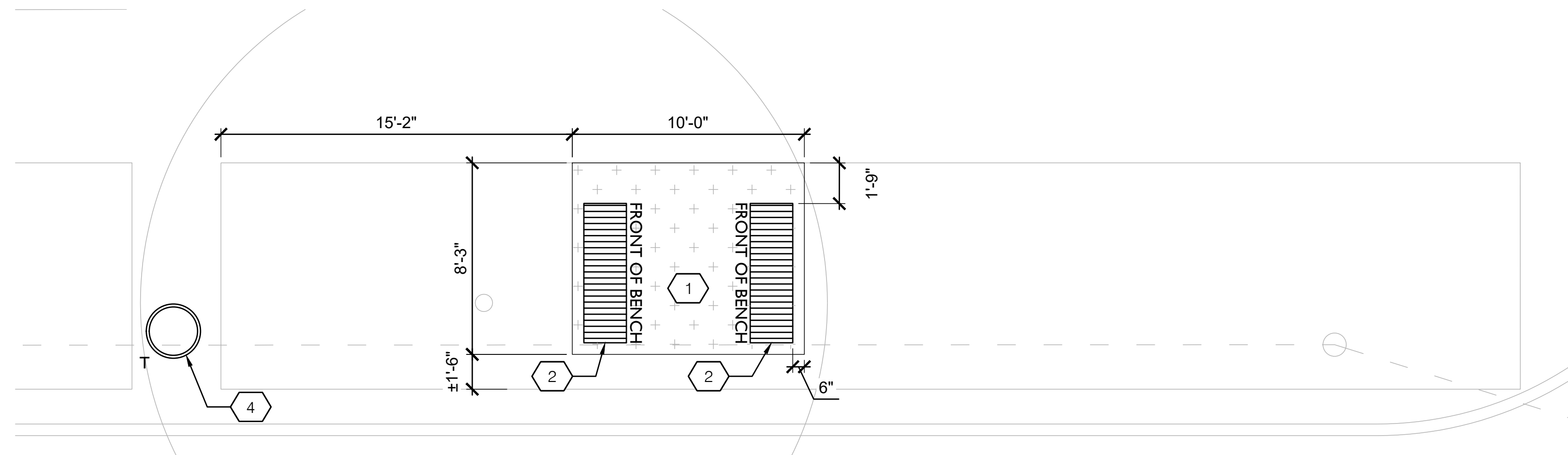
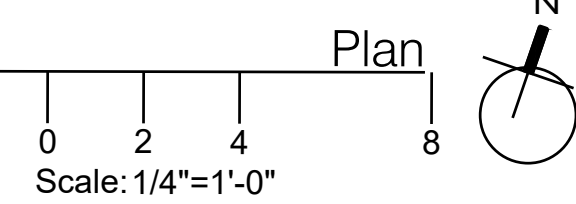

**5** MATERIALS ENLARGEMENT PLAN - ZONE 7  
Scale: 1/4"=1'-0"

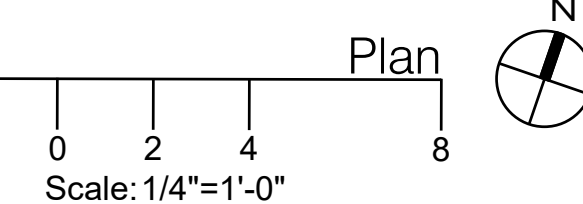

**LEGEND**

- |  |   |  |                                   |  |                                   |  |  |  |                                       |
|--|---|--|-----------------------------------|--|-----------------------------------|--|--|--|---------------------------------------|
|  | LIMIT OF WORK                             |  | NEW CONCRETE SIDEWALK, SEE 1/L910 |  | TRASH CANS, SEE 3/L910            |  | BENCH SWING, SEE 1/L911                    |  | TOUCH UP EXISTING CROSSWALKS, BY CITY |
|  | EXISTING TREES TO REMAIN AND BE PROTECTED |  | BENCHES, SEE 2/L910               |  | VERTICAL STORYTELLING, SEE 1/L912 |  | SOLAR-POWERED CHARGING STATION, SEE 2/L911 |  | ARTISTIC CROSSWALKS, SEE 2/L900       |
|  |   |  | BIKE RACKS, SEE 1/L910            |  | PLANTERS, SEE L250                |  | ART MURAL AT MEDIAN, SEE 3/L900            |  |                                       |

**NOTES**

1. MAINTAIN MAX 4.5% SLOPE AND 2% CROSS SLOPE ACROSS ALL SIDEWALKS.
2. CONTRACTOR TO VERIFY ALL DIMENSIONS IN FIELD.
3. SEE L250 FOR SITE FURNISHINGS SCHEDULE.
4. SEE L900 SERIES FOR DETAILS.



EXPANSION JOINTS	
ALL EXPANSION JOINT PAPER SHALL EXTEND 1" BELOW THE BOTTOM OF THE THICKER OF ADJOINING PAVEMENT SECTIONS.	
①	PLACE 1/2" PAPER EXPANSION JOINTS AT LOT LINES WHEN LOT LINES ARE BETWEEN 25' AND 50' APART.
②	PLACE ADDITIONAL 1/2" PAPER EXPANSION JOINTS SO THAT THE DISTANCE BETWEEN JOINTS DOES NOT EXCEED 15-2' WHEN LOT LINES ARE OVER 15-240' IN WIDTH.
③	PLACE 1/2" PAPER EXPANSION JOINTS AT EVERY SECOND LOT LINE AND CONTRACTION JOINT AT INTERVENING LOT LINE WHEN LOT LINES ARE LESS THAN 25' APART.
④	PLACE 1" PAPER EXPANSION JOINTS AT CURB AND BUILDING OR PROPERTY LINE OR AT ALTERNATE POSITION AS SHOWN FOR DRIVEWAY.
⑤	PLACE 1" PAPER EXPANSION JOINTS AT CURB AND BUILDING OR PROPERTY LINE FOR FULL WIDTH SIDEWALK EXCEEDING 7' IN WIDTH.
⑥	PLACE 1" PAPER EXPANSION JOINTS AT CURB CIRCLES OR AT ALTERNATE POSITION AS SHOWN.
⑦	PLACE 1" PAPER EXPANSION JOINTS AT INTERSECTIONS OF SERVICE WALKS AND SIDEWALKS AND SERVICE WALKS AND CURBS.
⑧	PLACE 1" PAPER EXPANSION JOINTS AT MARGIN FLAGS AT CROSSWALKS.
⑨	PLACE 1" PAPER EXPANSION JOINTS AT ALLEY APRONS.
⑩	PLACE 1/2" PAPER EXPANSION JOINT BOTH SIDES OF SIDEWALK FLAG ABUTTING TREE AND ON CENTERLINE JOINT.
CONTRACTION JOINTS	
⑪	PLACE CONTRACTION JOINTS AT INTERVALS OF NOT LESS THAN 5' NOR MORE THAN 17' ON WALKS 5' WIDE OR WIDER, INCLUDING FULL WIDTH WALKS.
⑫	PLACE CONTRACTION JOINTS AT INTERVALS OF NOT LESS THAN 4' NOR MORE THAN 17' ON WALKS 4' WIDE.
⑬	PLACE CONTRACTION JOINTS AT THE MARGIN LINE ON FULL WIDTH WALKS (OPTIONAL).
DRIVEWAYS	
⑭	PLACE CONTRACTION JOINTS IN DRIVEWAYS SO THAT NO SLAB WILL EXCEED THE DIMENSIONS OF 15' BY 15'.
⑮	PLACE 1" PAPER EXPANSION JOINTS ON ALL SIDES OF COMMERCIAL DRIVES.
⑯	PLACE CONTRACTION OR CONTRACTION JOINT ON CENTERLINE WHEN WIDTH OF DRIVEWAY EXCEEDS 15'
⑰	PLACE 1/2" PAPER EXPANSION JOINTS ON BOTH SIDES OF RESIDENTIAL DRIVEWAYS.
IF DRIVEWAY EDGE IS WITHIN 2' OF LOT LINE, PLACE THIS EXPANSION PAPER AT PROPERTY LINE.	

CITY OF DETROIT  
CITY ENGINEERING DEPARTMENT  
DIVISION OF PUBLIC WORKS  
SIDEWALK JOINTING  
STANDARD  
REVISED DATE: METRIC TO ENGLISH UNIT CONVERSION 02/2002  
C-4462 1/21

- NOTES:
- ARTWORK TO BE PROVIDED AS VECTOR FILE.
  - ANTI-SKID FORMULA SHALL BE USED AT ALL PAINTED CROSSWALK SURFACES.
  - ARTISTIC CROSSWALKS SHALL NOT BE MADE TO BE RETRO-REFLECTIVE.

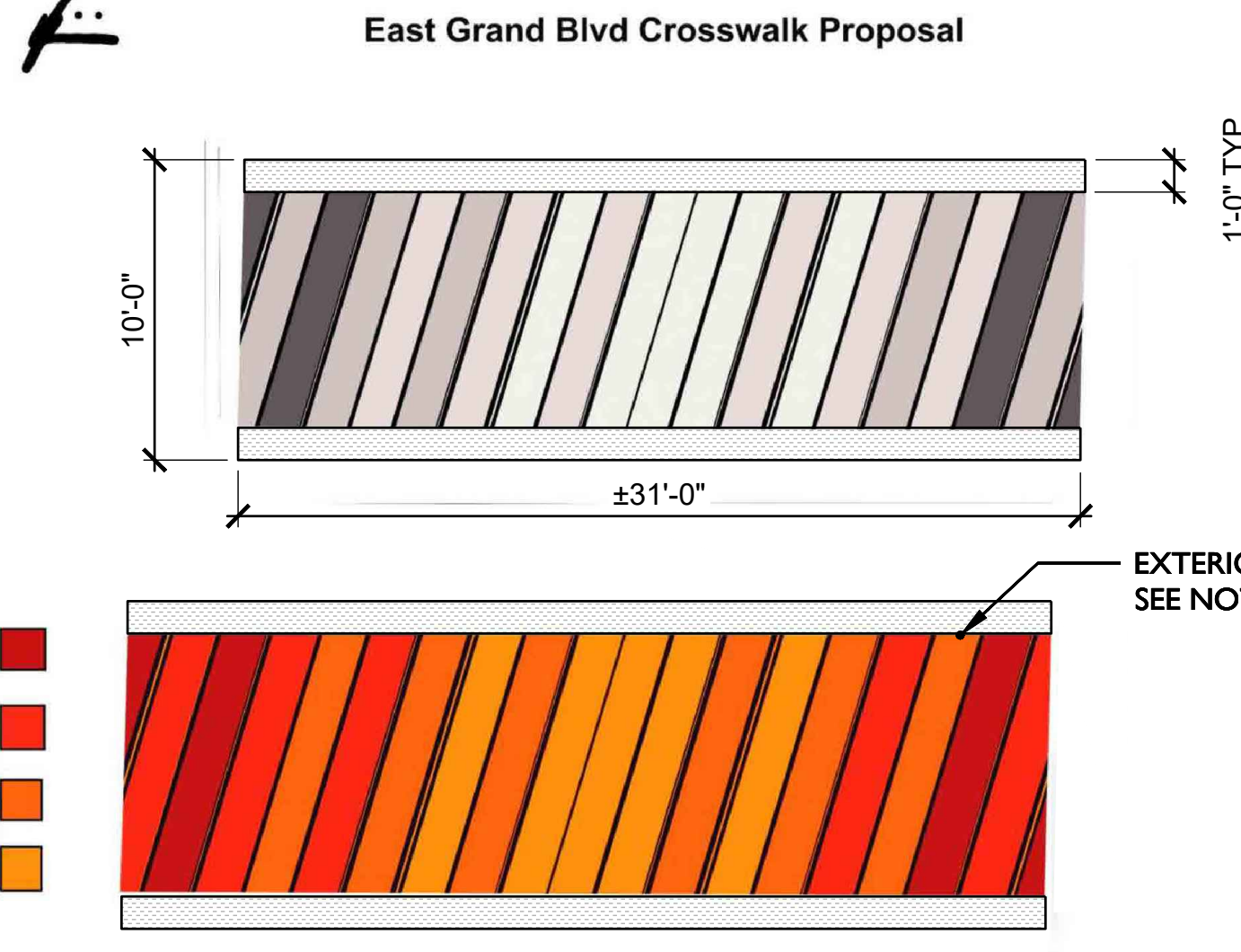

Intersection of Oakland and East Grand Boulevard

IANIA CORTEZ 2022

- NOTES:
- ARTWORK TO BE PROVIDED AS VECTOR FILE.
  - ANTI-SKID FORMULA SHALL BE USED AT ALL PAINTED CROSSWALK SURFACES.
  - ARTISTIC CROSSWALKS SHALL NOT BE MADE TO BE RETRO-REFLECTIVE.

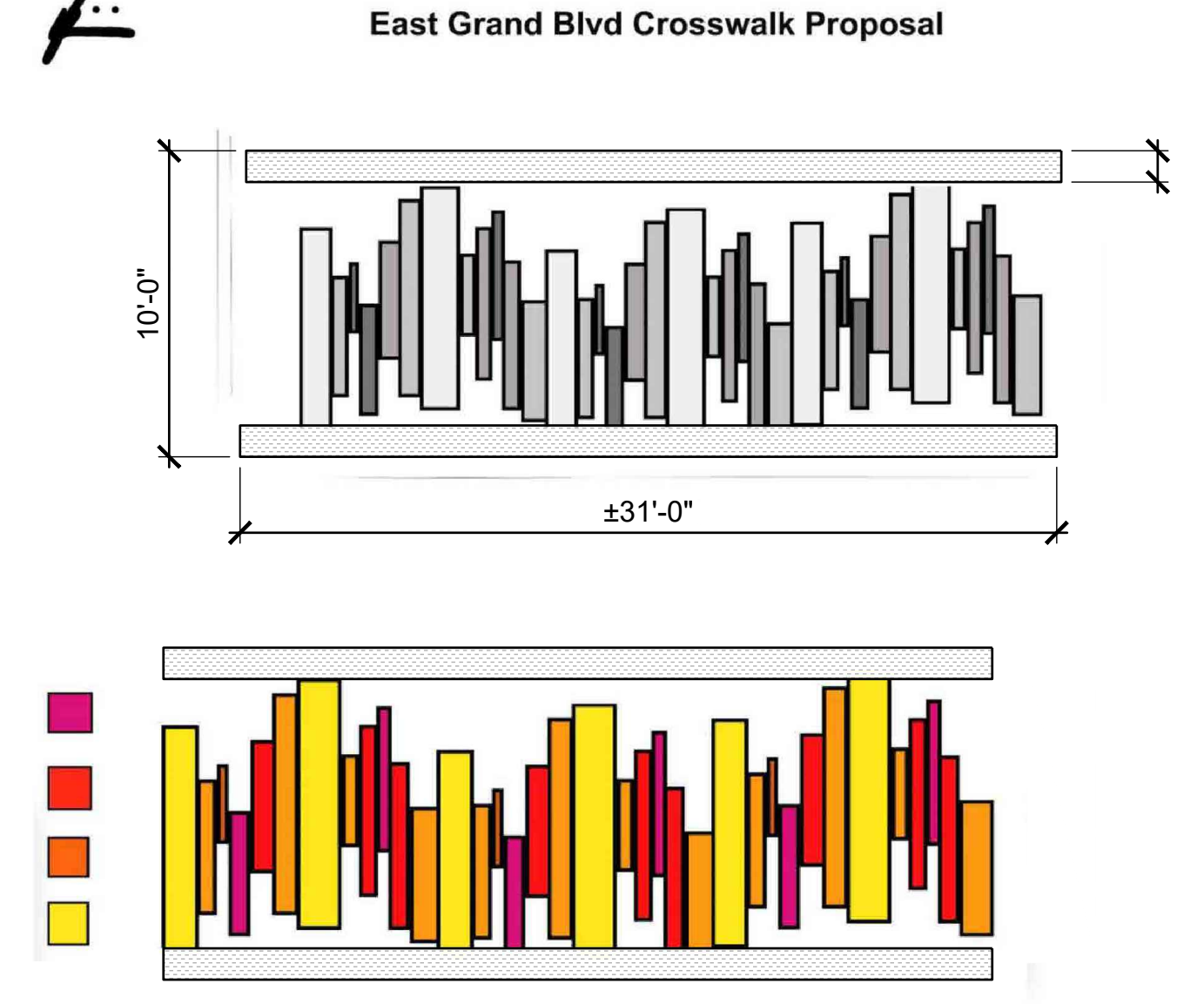

Intersection of Oakland and East Grand Boulevard

**B** SIDEWALK AND DRIVEWAY JOINTING TEXT  
NTS

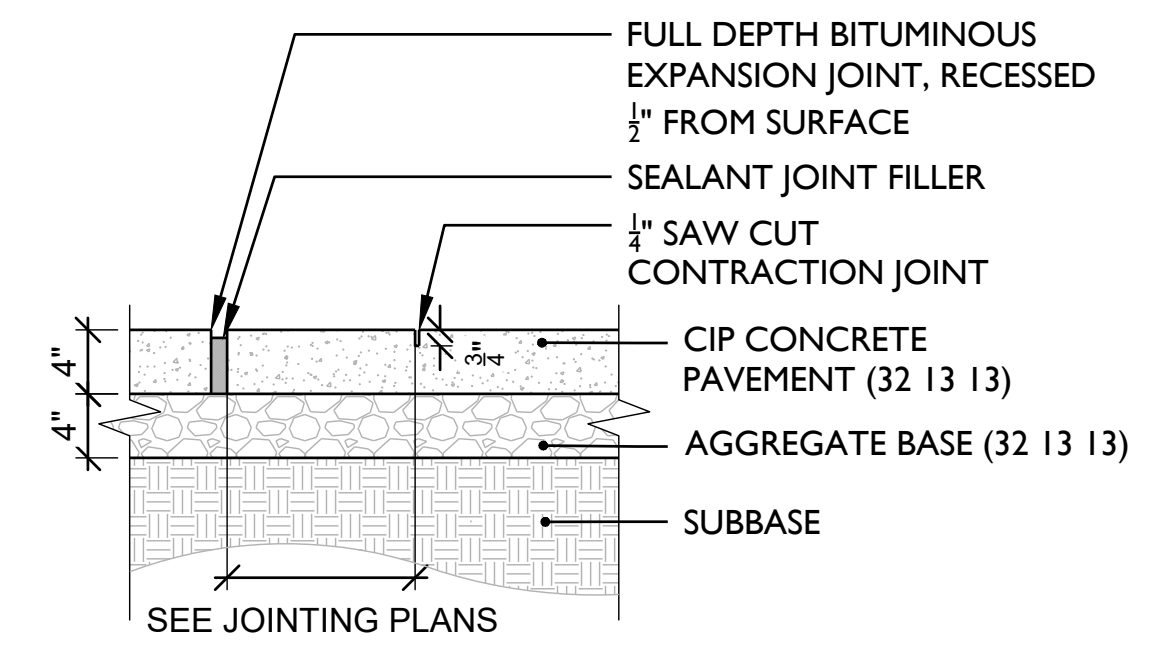

**A** DETAIL OF STANDARD SIDEWALK  
Scale: 1"=1'-0"

**1** STANDARD SIDEWALK, TYP.  
Scale: As Noted

**A** TYPE 1  
Scale: NTS

**2** ARTISTIC CROSSWALK  
Scale: NTS

**B** TYPE 2  
Scale: 1"=1'-0"

PLAN

NOTE:  
ARTWORK TO BE PROVIDED AS VECTOR FILE.

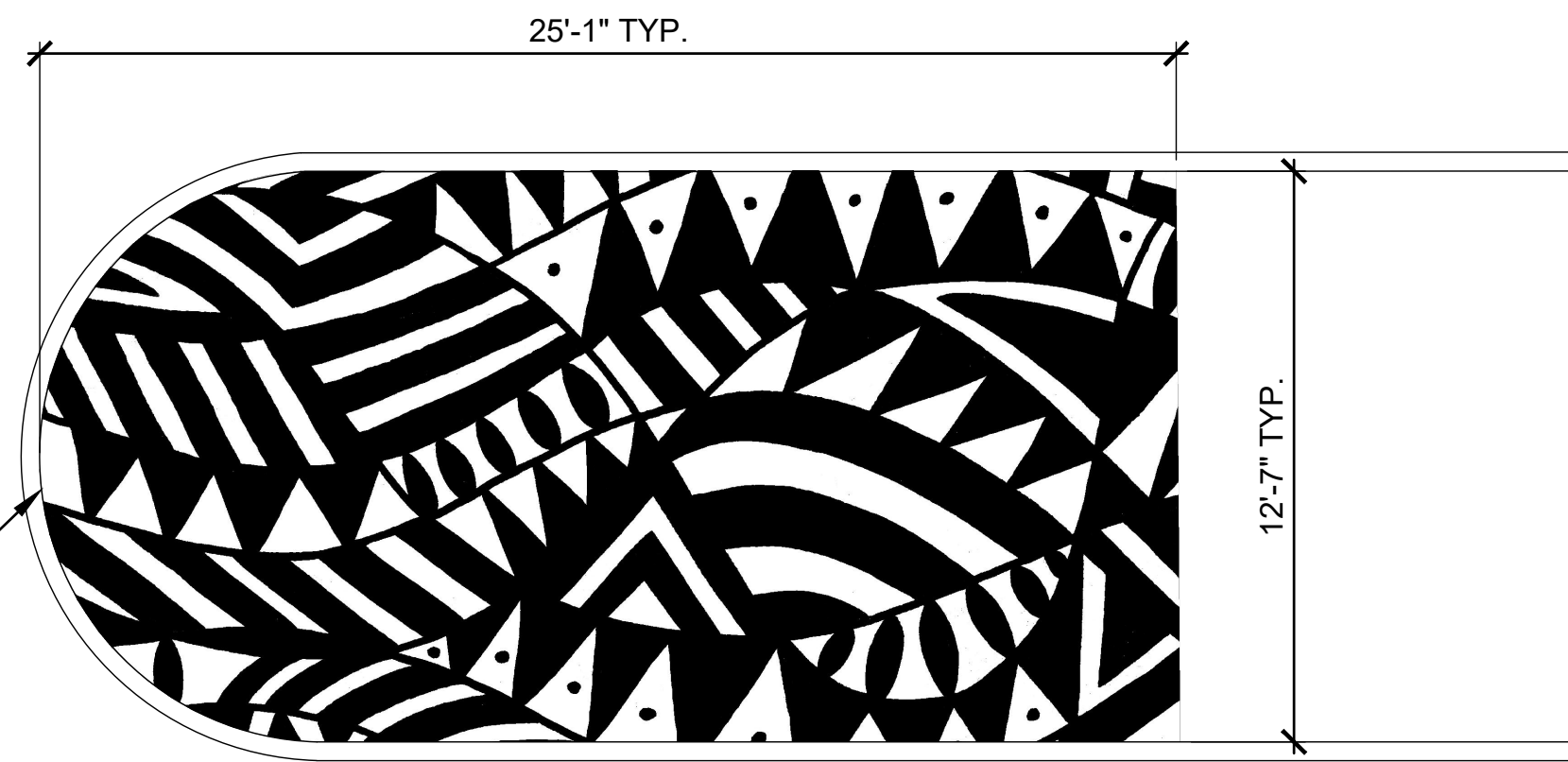

**A** TYPE 1 TYP.

**3** ART MURAL AT MEDIAN, TYP.  
Scale: NTS

NOTE:  
ARTWORK TO BE PROVIDED AS VECTOR FILE.



**B** TYPE 2

**spackman  
mossop  
michaels**  
440 Burroughs Street  
Suite 696  
Detroit | MI | 48202  
T: 313.720.1055  
LANDSCAPE ARCHITECTS

**EAST GRAND BOULEVARD  
STREETSCAPE TRANSFORMATION  
E GRAND BLVD, DETROIT**

STATUS:  
100% CONSTRUCTION DOCUMENTS

DATE:  
21 SEPTEMBER 2022

REVISION NO.	DESCRIPTION	DATE
1	ROW PERMIT REVIEW	07/29/22



SMM Project No:  
21014

Sheet No:  
**SITE DETAILS**

Sheet No:  
**L900**







**EAST GRAND BOULEVARD  
STREETSCAPE TRANSFORMATION  
E GRAND BLVD, DETROIT**

**STATUS:**  
100% CONSTRUCTION DOCUMENTS

**DATE:**  
21 SEPTEMBER 2022

**REVISION**  
NO. DESCRIPTION DATE

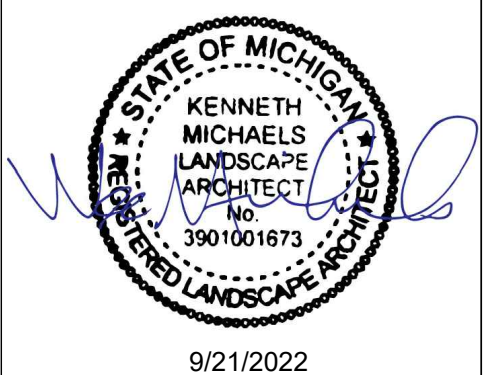

SMM Project No:  
21014  
Sheet No:  
**SITE DETAILS  
SITE FURNISHINGS**

Sheet No:  
**L911**

- NOTES:**  
1. COLOR TBD BY LANDSCAPE ARCHITECT.  
2. PERFORATION PATTERN TBD BY LANDSCAPE ARCHITECT.

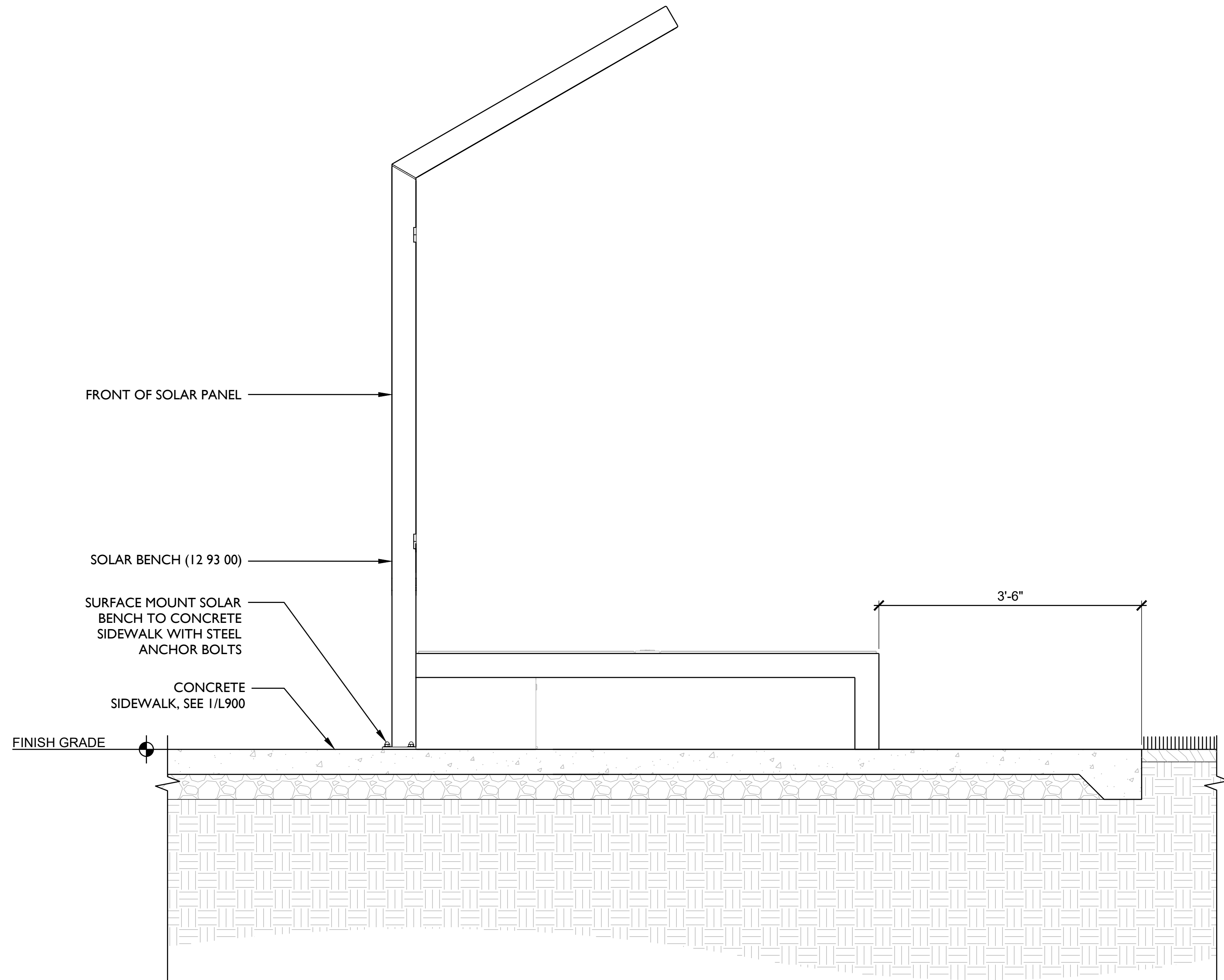
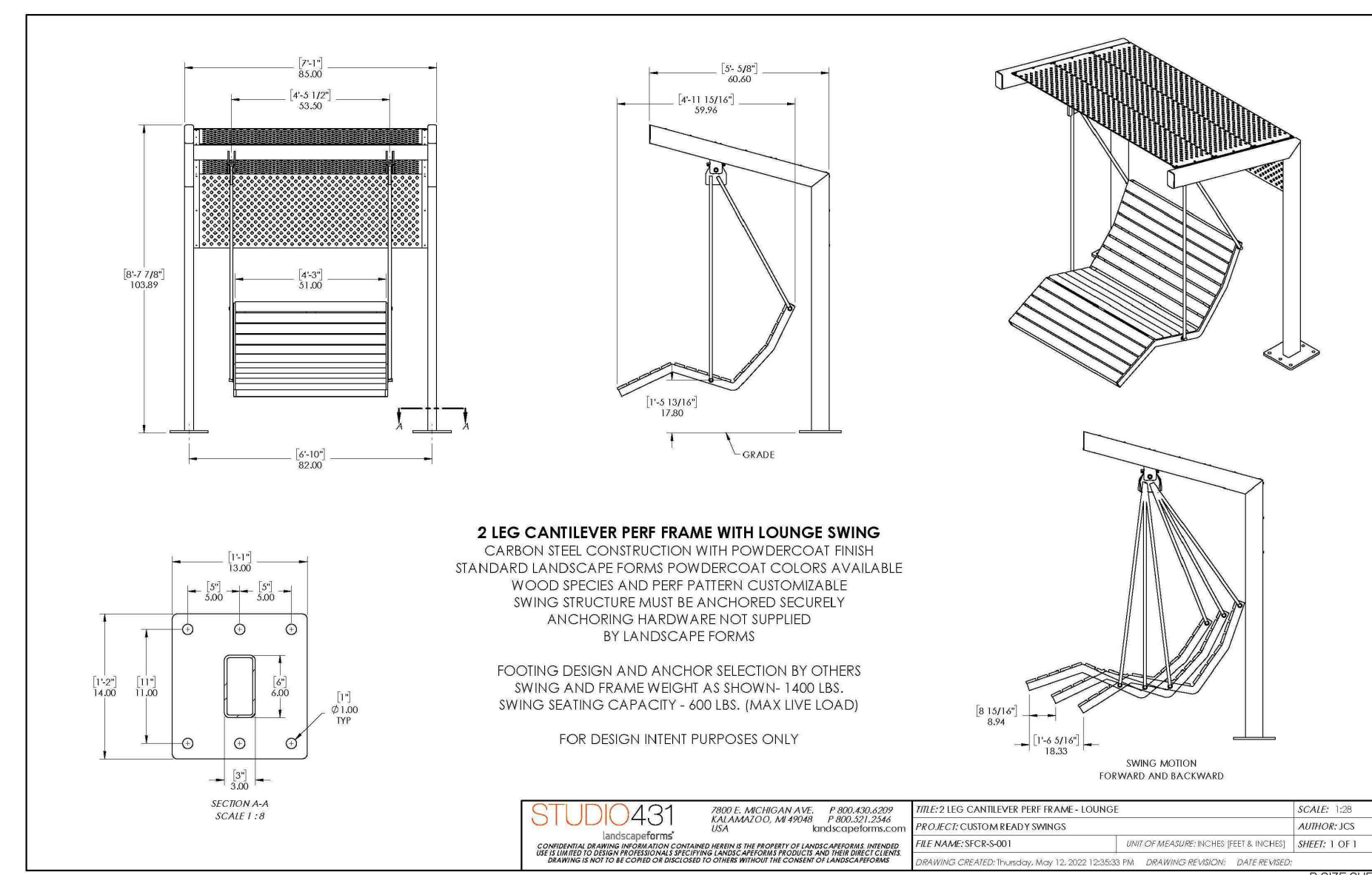

**1** BENCH SWING, TYP.  
Scale: NTS

DETAIL

**2** SOLAR BENCH, TYP.  
Scale: 1"=1'-0"

DETAIL



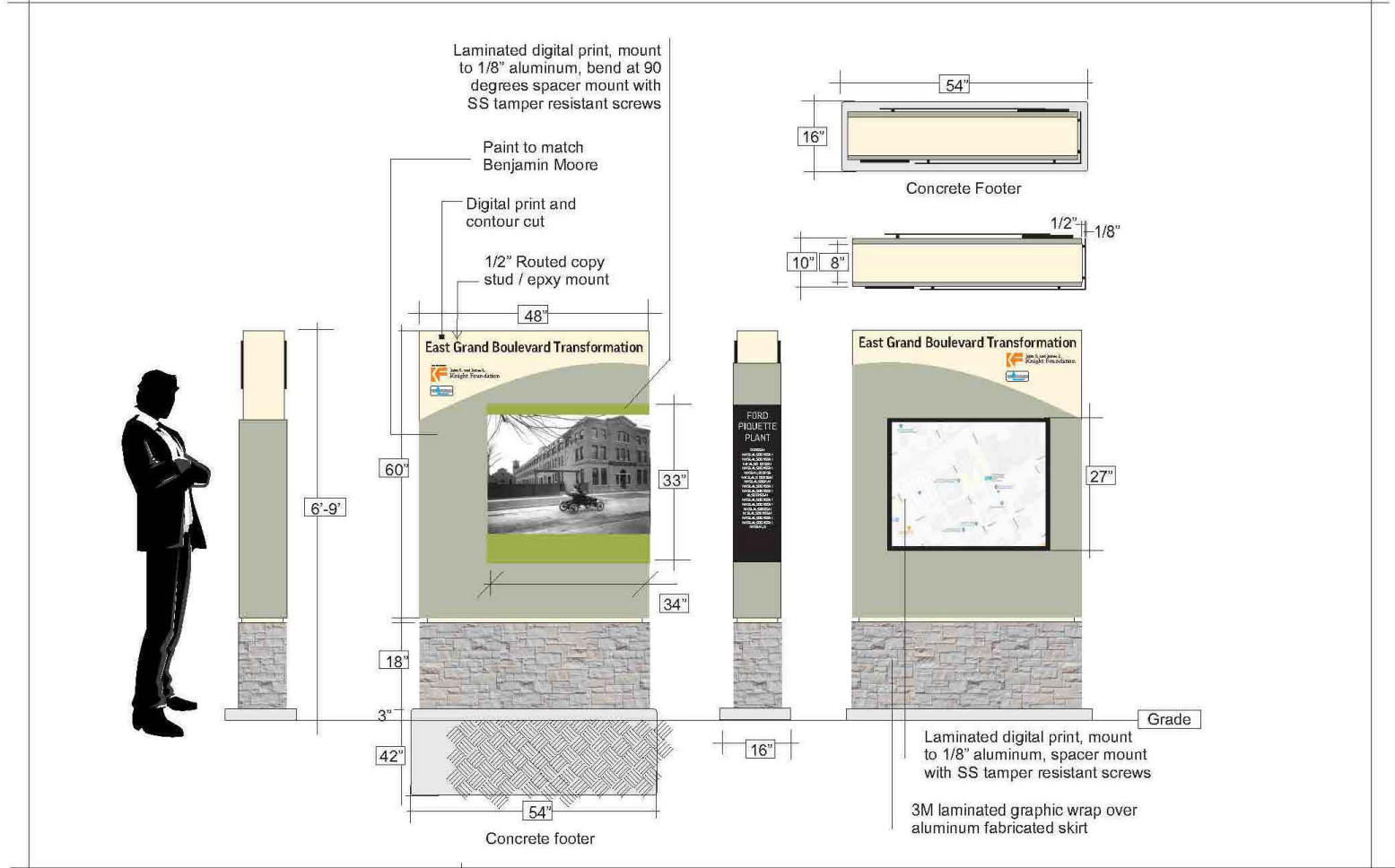

East Grand Boulevard Transformation Sign Type A  
Banner Sign Company  
Nicholas Plach  
6338 Russell Street, Detroit, MI 48211  
Voice 313.758.6737 Fax 248.545.0742  
www.bannermfg.com info@bannermfg.com

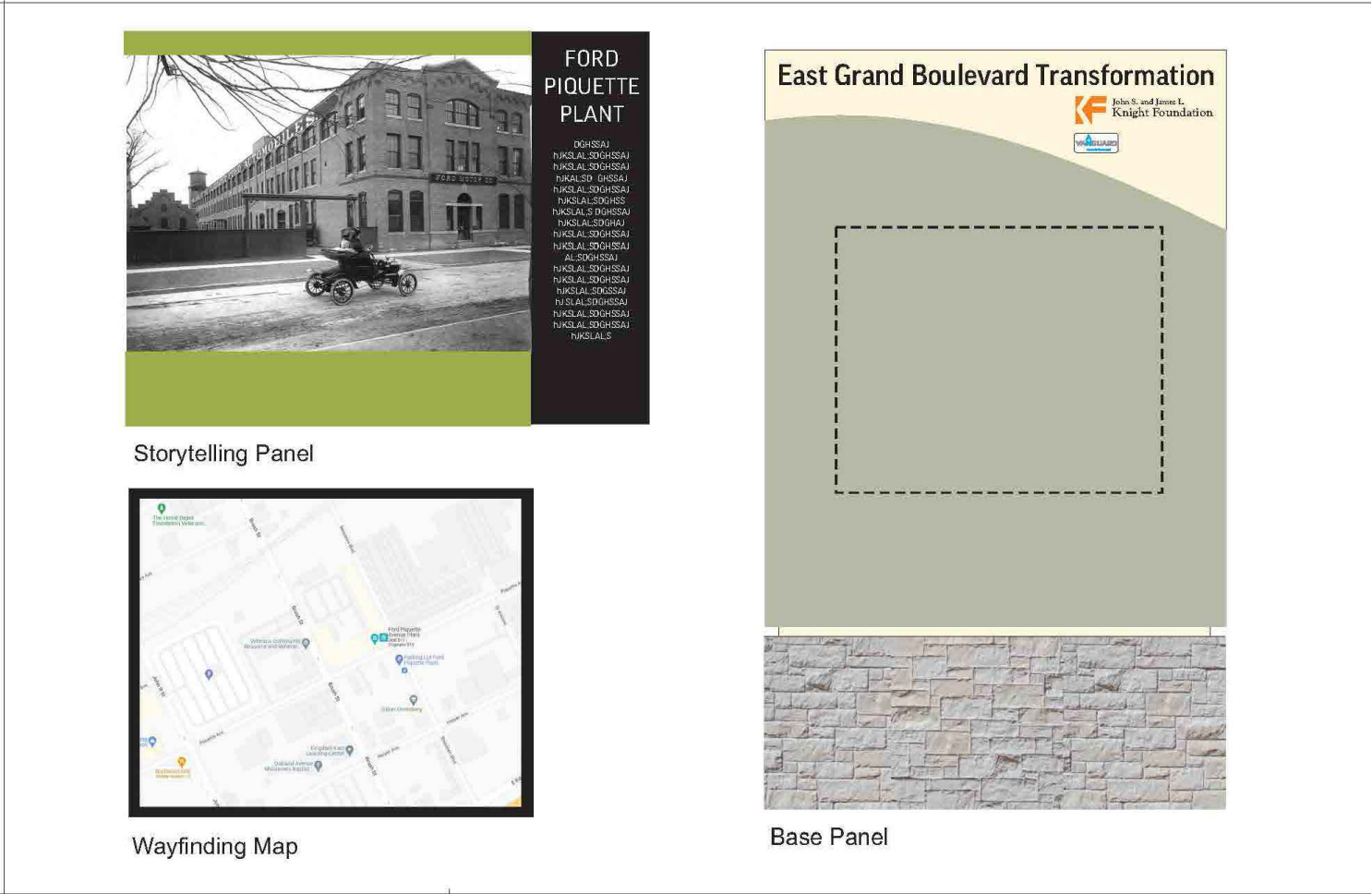

East Grand Boulevard Transformation Sign Type A: Content  
Banner Sign Company  
Nicholas Plach  
6338 Russell Street, Detroit, MI 48211  
Voice 313.758.6737 Fax 248.545.0742  
www.bannermfg.com info@bannermfg.com

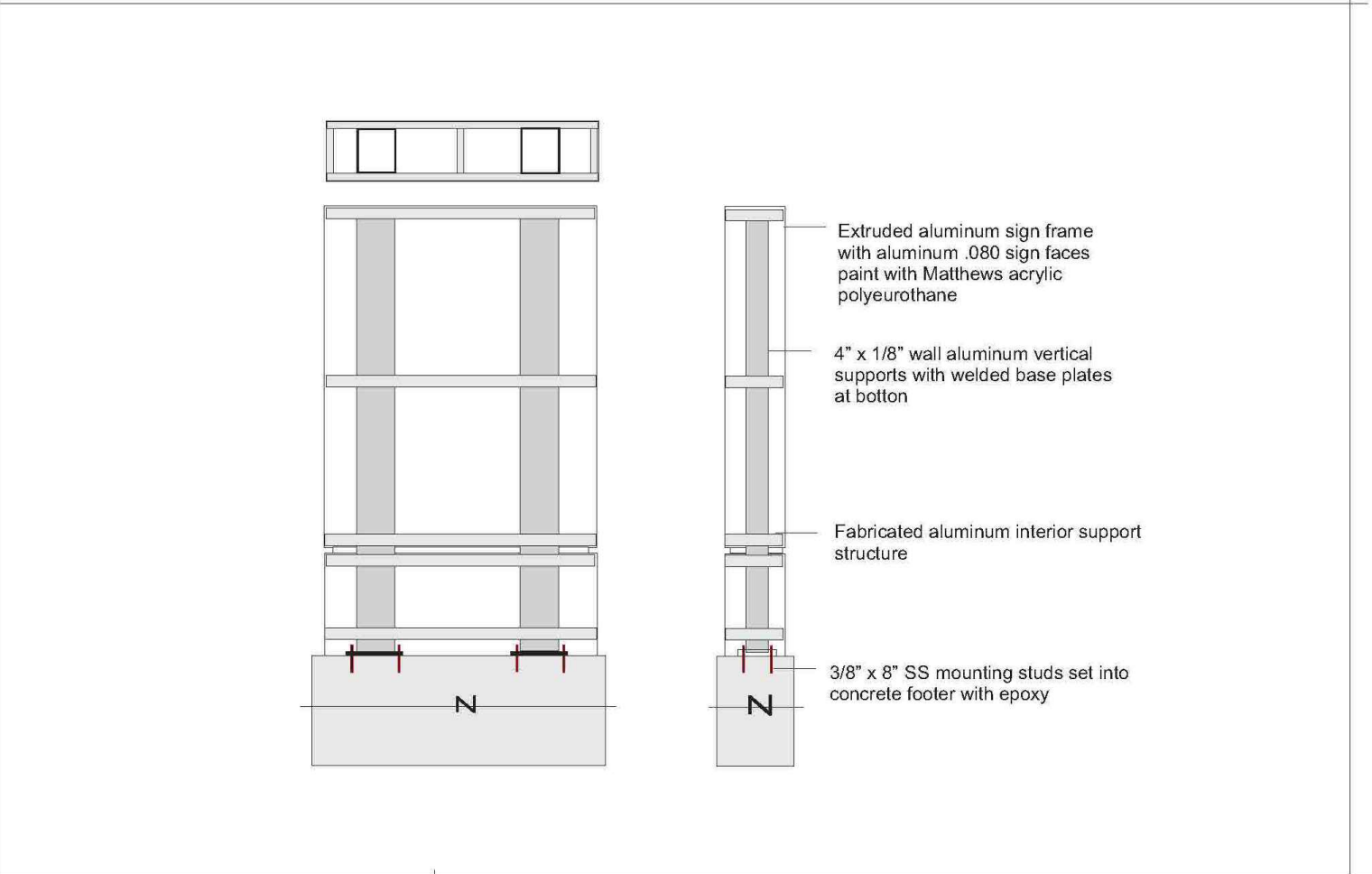

East Grand Boulevard Transformation Sign Type A: Detail  
Banner Sign Company  
Nicholas Plach  
6338 Russell Street, Detroit, MI 48211  
Voice 313.758.6737 Fax 248.545.0742  
www.bannermfg.com info@bannermfg.com

A SIGN TYPE A

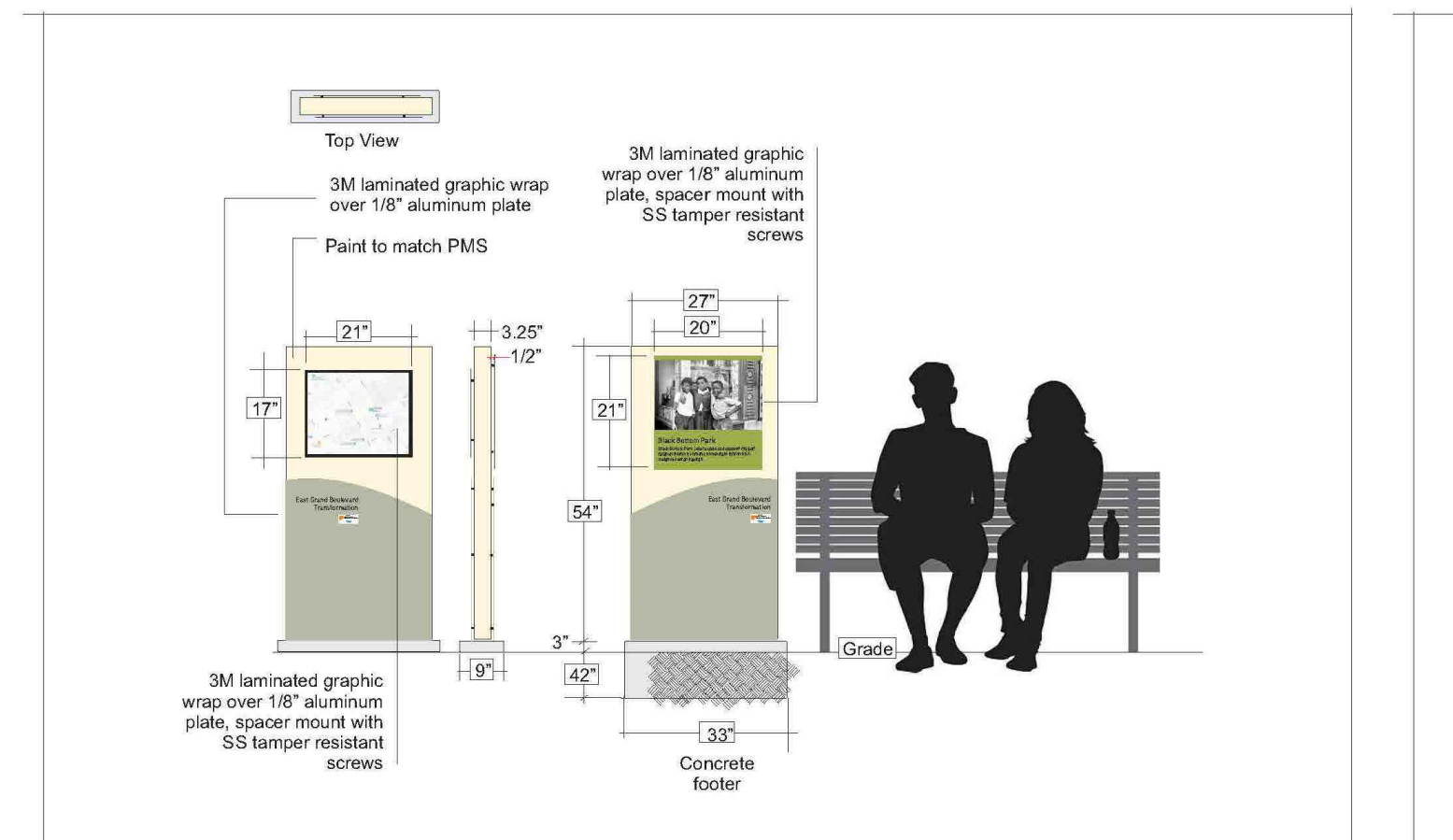

East Grand Boulevard Transformation Sign Type B: Elevation  
Banner Sign Company  
Nicholas Plach  
6338 Russell Street, Detroit, MI 48211  
Voice 313.758.6737 Fax 248.545.0742  
www.bannermfg.com info@bannermfg.com

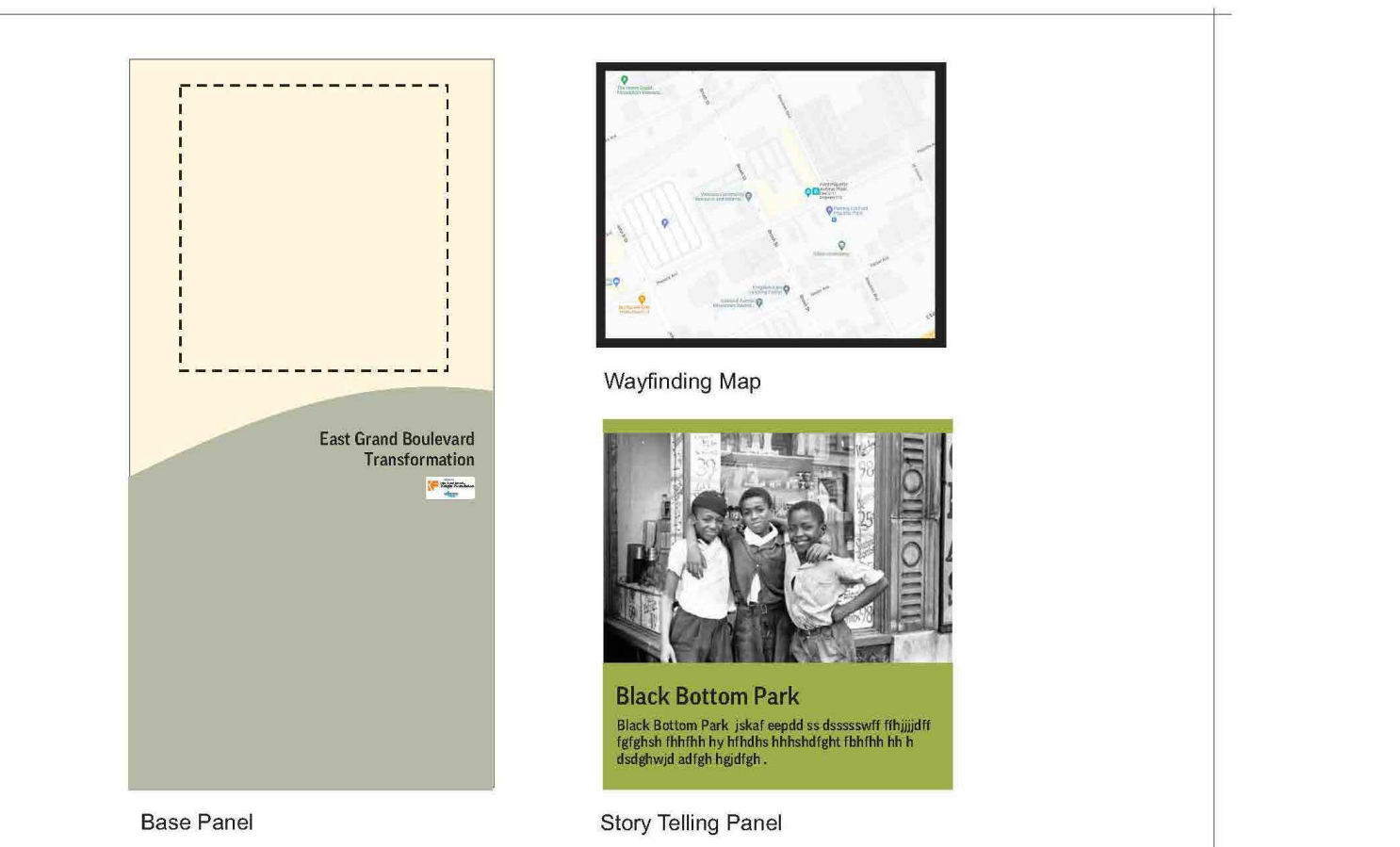

East Grand Boulevard Transformation Sign Type B: Content  
Banner Sign Company  
Nicholas Plach  
6338 Russell Street, Detroit, MI 48211  
Voice 313.758.6737 Fax 248.545.0742  
www.bannermfg.com info@bannermfg.com

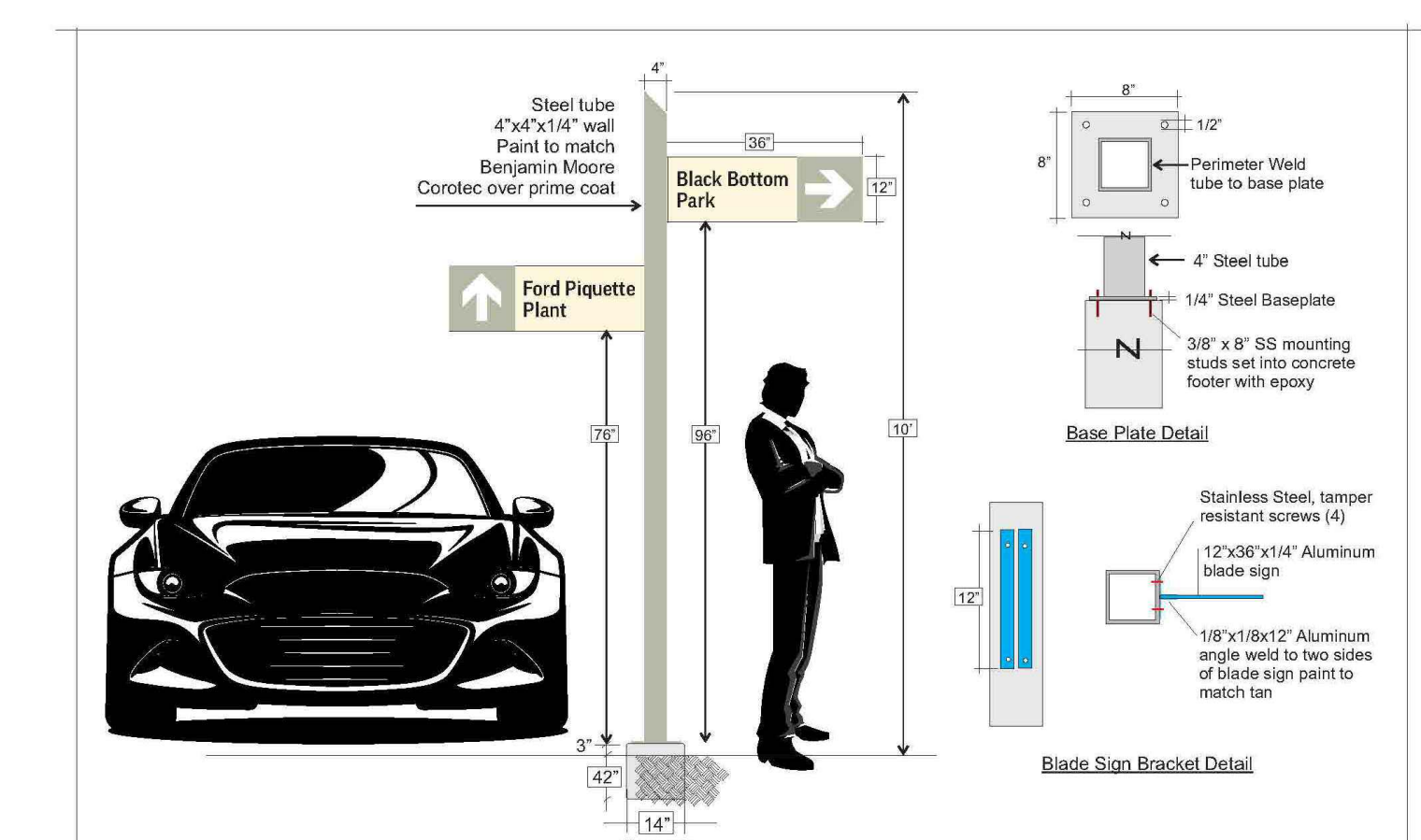

East Grand Boulevard Transformation Sign Type C  
Banner Sign Company  
Nicholas Plach  
6338 Russell Street, Detroit, MI 48211  
Voice 313.758.6737 Fax 248.545.0742  
www.bannermfg.com info@bannermfg.com

B SIGN TYPE B

C SIGN TYPE C

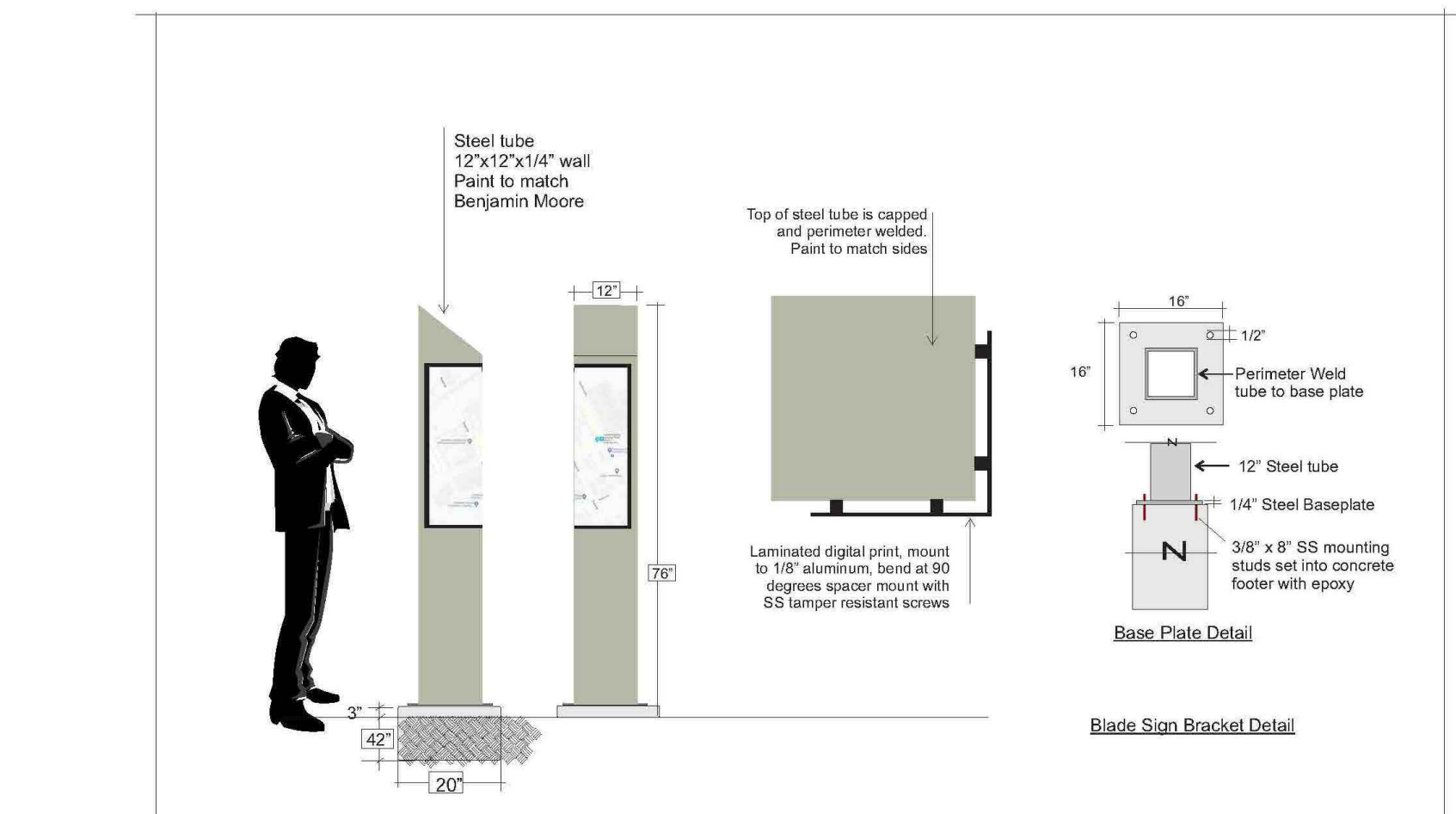

East Grand Boulevard Transformation Sign Type D  
Banner Sign Company  
Nicholas Plach  
6338 Russell Street, Detroit, MI 48211  
Voice 313.758.6737 Fax 248.545.0742  
www.bannermfg.com info@bannermfg.com

D SIGN TYPE D

1 SIGNAGE, TYP.  
Scale: NTS

- NOTES:  
1. OWNER TO CONFIRM FINAL LOCATION OF ALL SIGNAGE PRIOR TO INSTALLATION.  
2. CONTRACTOR TO PROVIDE SHOP DRAWINGS, INCLUDING PLANS AND ELEVATIONS, INDICATING OVERALL SIGNAGE DIMENSIONS, TEXT LOCATION, FONT SIZE, STYLE AND COLOR FOR APPROVAL PRIOR TO PROCUREMENT AND INSTALLATION.  
3. CONTRACTOR SHALL SUBMIT SAMPLES OF MATERIALS, FINISHES, AND COLORS OF EACH EXPOSED PRODUCT FOR OWNER'S APPROVAL.  
4. CONTRACTOR SHALL SUBMIT DIGITAL COPY AS A PDF FILE FOR MANUFACTURER'S WRITTEN MAINTENANCE INSTRUCTIONS.  
5. CONTRACTOR SHALL PROVIDE MANUFACTURER'S STANDARD WARRANTY PRIOR TO PROJECT CLOSEOUT.  
6. ALL SIGNAGE FOOTINGS BY SIGNAGE CONTRACTOR.

DETAIL

EAST GRAND BOULEVARD  
STREETSCAPE TRANSFORMATION  
E GRAND BLVD, DETROIT

STATUS:  
100% CONSTRUCTION DOCUMENTS

DATE:  
21 SEPTEMBER 2022

REVISION table with columns: NO., DESCRIPTION, DATE



SMM Project No:  
21014

Sheet No:  
SITE DETAILS  
SIGNAGE

Sheet No:  
L912